

## Before installation

- This equipment complies with EN/IEC 61000-3-12 provided that the short-circuit power  $S_{sc}$  is greater than or equal to  $S_{sc}$  of Table 4 at the interface point between the user's supply and the public system. It is the responsibility of the installer or user of the equipment to ensure, by consultation with the distribution network operator if necessary, that the equipment is connected only to a supply with a short-circuit power  $S_{sc}$  greater than or equal to  $S_{sc}$  of Table 4.

**Table 4**

Combinations	FBQ35D	FBQ50D	FBQ60D	FBQ71D	FBQ100D	FBQ125D	FBQ140D
RZQG71L	2 (—)	—	—	1 (—)	—	—	—
RZQG100L	3 (2.31)	2 (1.30)	—	—	1 (0.73)	—	—
RZQG125L	4 (3.33)	3 (2.32)	2 (2.05)	—	—	1 (0.74)	—
RZQG140L	4 (3.33)	3 (2.32)	—	2 (2.05)	—	—	1 (0.74)
RZQSG71L	2 (1.10)	—	—	1 (1.22)	—	—	—
RZQSG100L	2 (1.65)	2 (—)	—	—	1 (—)	—	—
RZQSG125L	4 (3.33)	3 (2.32)	2 (2.05)	—	—	1 (0.74)	—
RZQSG140L	4 (3.33)	3 (2.32)	—	2 (2.05)	—	—	1 (0.74)

Number of indoor units ( $S_{sc}$  [MVA])

## Wiring example

- If the combination of units corresponds to any in Table 3, use separate power supplies. (See Figure 15)

**Table 3**

1 x FBQ35D	+ RXS35L
2 x FBQ60D	+ RR100/125B or RQ100/125B
2 x FBQ71D	+ RR100/125B or RQ100/125B
4 x FBQ50D	+ RZQ200C
3 x FBQ60D	+ RZQ200C
3 x FBQ71D	+ RZQ200C
2 x FBQ100D	+ RZQ200C
4 x FBQ60D	+ RZQ200C
2 x FBQ125D	+ RZQ200C

- If the combination of units is one from Table 4, a separate power supply according to Figure 15 can be used. If a separate power supply, according to Figure 15, is used, then there is no need to consult the distribution network operator.
- If there is requirement to use common power supply for the units from Table 4, the connection of the units complies with EN/IEC 61000-3-12<sup>(b)</sup>.

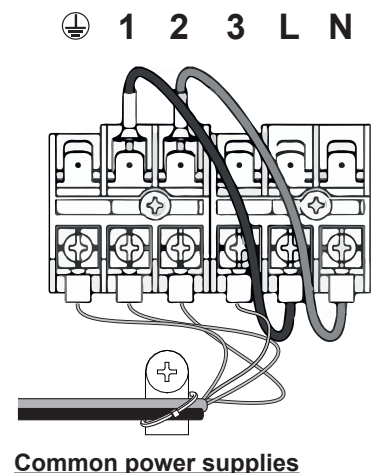
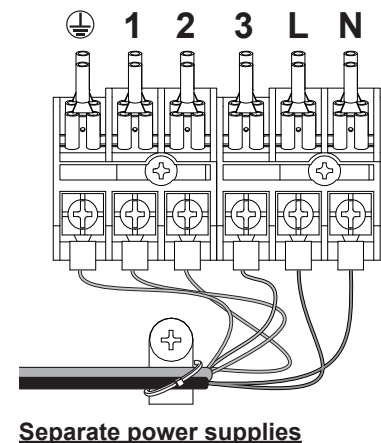

(b) European/International Technical Standard setting the limits for harmonic currents produced by equipment connected to low-voltage systems with input current >16 A and ≤75 A per phase.

## Wiring diagram

### Indoor unit

A1P	Printed circuit board	M1P	Motor (drain pump)	TC	Signal transmission circuit
A2P	Printed circuit board (fan)	R1	Resistor (current sensor)	X1M	Terminal strip (power supply)
C1	Capacitor			X2M	Terminal strip (power supply)
C105	Capacitor			X3M	Terminal block (control)
DS1	Selector switch			Z1F	Noise filter
F1U	Fuse ·T,3.15A,250V·	R2	Resistor (current sensor)	Z1C	Ferrite core
F2U	Fuse ·T,5A,250V·	R1T	Thermistor (suction)	Z2C	Ferrite core
F3U	Fuse ·T,6.3A,250V·	R2T	Thermistor (liquid)	Q1DI	Earth leakage breaker
HAP	Indication lamps	R3T	Thermistor (coil)	Connector (optional accessories)	
K1R	Magnetic relay	S1L	Float switch	X28A	Connector (power supply for wiring)
K2R	Magnetic relay	V1R	Diode bridge	X33A	Connector (for wiring)
L1R	Reactor	PS	Switching power supply	X35A	Connector (power supply for adaptor)
M1F	Motor (indoor fan)	RC	Signal receiver circuit		

- Screw terminal    ⊗ Connector    - - - Field wiring
- In case of a multi-indoor-unit system with parallel operation, refer to the documentation of the indoor units.
- For details, refer to the wiring diagram attached to the outdoor unit.
- When using a central remote control, connect it to the unit according to the installation manual.
- When connecting the input wires from outside, forced OFF or On/OFF control operation can be selected by remote control. For more information, refer to the installation manual.
- For a multi-indoor-unit system with parallel operation, the connection ratio (number of indoor units you can connect to the outdoor unit) is different. Before connecting, refer to the Technical data or the General catalogue.
- For how to switch between the main unit and the sub units, refer to the installation manual of the remote control.
- Colours: blk:black; red:red; blu:blue; wht:white; grn:green; ylw:yellow; brn:brown; org:orange; pnk:pink

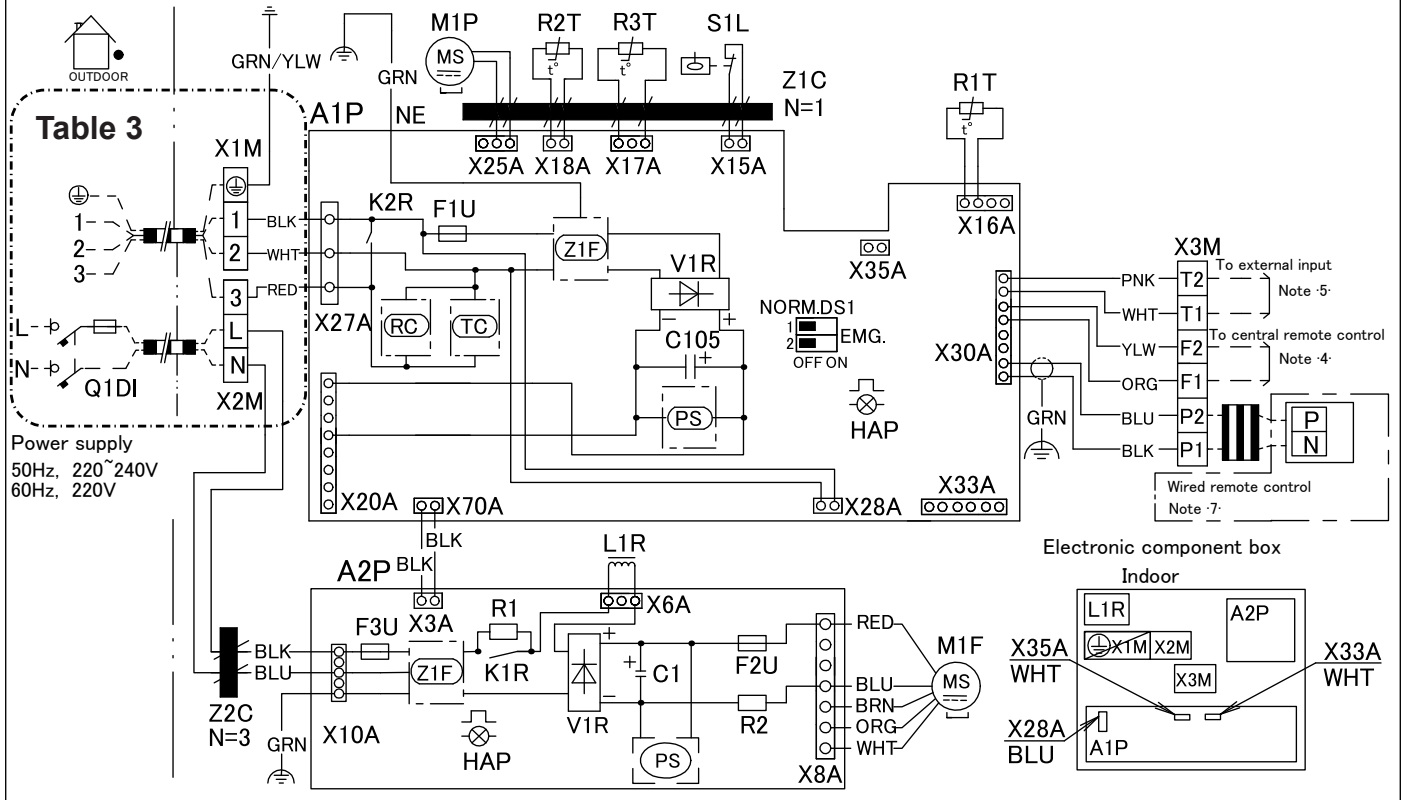

Table 4

