

WATER COOLED VRV APPLICATION REFERENCE



JMI-0107

Organization:
DAIKIN INDUSTRIES, LTD.
AIR CONDITIONING MANUFACTURING DIVISION

Scope of Registration:
THE DESIGN/DEVELOPMENT AND MANUFACTURE OF
COMMERCIAL AIR CONDITIONING, HEATING,
COOLING, REFRIGERATING EQUIPMENT, HEATING
EQUIPMENT, RESIDENTIAL AIR CONDITIONING
EQUIPMENT, HEAT RECLAIM VENTILATION, AIR
CLEANING EQUIPMENT, COMPRESSORS AND VALVES.



JQA-1452

Organization:
DAIKIN INDUSTRIES
(THAILAND) LTD.

Scope of Registration:
THE DESIGN/DEVELOPMENT AND MANUFACTURE OF
AIR CONDITIONERS AND THE COMPONENTS
INCLUDING COMPRESSORS USED FOR THEM



EC99J2044

All of the Daikin Group's business
facilities and subsidiaries in Japan
are certified under the ISO 14001
international standard for
environment management.

Dealer

DAIKIN INDUSTRIES, LTD.

Head Office:
Umeda Center Bldg., 2-4-12, Nakazaki-Nishi,
Kita-ku, Osaka, 530-8323 Japan

Tokyo Office:
JR Shinagawa East Bldg., 2-18-1, Konan,
Minato-ku, Tokyo, 108-0075 Japan

http://www.daikin.com/global_ac/

©All rights reserved
Printed in Japan 02/12/001 AK

• Specifications, designs and other content appearing in this brochure are current as of February 2012 but subject to change without notice.

WATER COOLED **VRV**
APPLICATION REFERENCE





Message

Daikin Industries launched the world's first air-cooled VRV system in 1982. Highly evaluated within the market for features such as individual control, energy-saving operation, flexible design, easy installation and maintenance, it was followed by the release of the water-cooled VRV system in 2002. The water-cooled VRV system is recognized for its high performance, high quality, and high reliability. It is widely applied in office buildings, hotels, shopping centers, hospitals, stadiums and residential use, from small buildings to skyscrapers with over 30 stories.

As buildings become larger, installing the outdoor units within limited space is a growing issue for architects. The water-cooled VRV system is an optimal solution for any building because its flexible layout makes it possible to install condensers indoors. It is also optimal for renovation from chiller system, since existing cooling towers and water piping can be reused. Just adding a BP unit, a heat recovery system capable of simultaneous cooling / heating operation can be provided. Furthermore, use of geothermal heat is innovative and environmentally friendly solution that might grow more popular in the future.

This brochure shows just a part of our many successes around the world. We are confident you will appreciate how neatly the VRV system fits into a variety of architectures, application and weather conditions.

A handwritten signature in black ink, appearing to read 'Yoshihiro Mineno'.

Yoshihiro Mineno

General Manager
Global Operations Div.

GLOBAL MAP OF DAIKIN PROJECTS

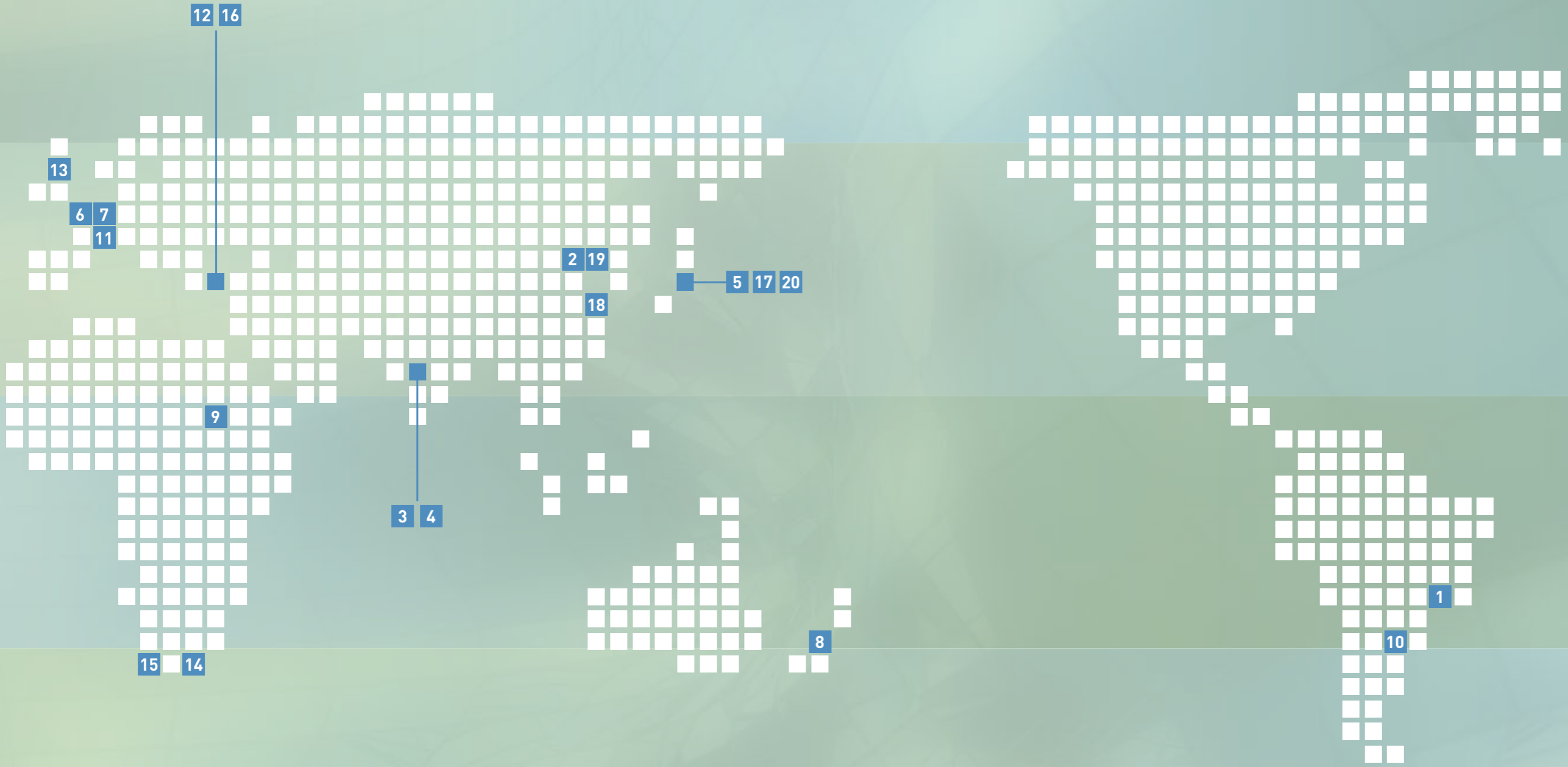

* These numbers correspond to the numbers listed before each project name.

INDEX



OFFICE	1	Banco Santander S.A.	P6
		São Paulo, Brazil	
	2	News Plaza	P10
		Beijing, China	
	3	Kirloskar Brothers Ltd.	P12
		Pune, India	
	4	SUZLON Energy Ltd.	P16
		Pune, India	
	5	Hommachi Minami Garden City	P22
	Osaka, Japan		
6	Magna Porta Almelo	P26	
	Almelo, Netherlands		
7	Ordina Groningen	P30	
	Groningen, Netherlands		
8	Clarendon Towers	P34	
	Christchurch, New Zealand		
9	The NTC (National Telecom Corporation) Tower	P36	
	Khartoum, Sudan		
HOSPITAL	10	Hospital Finochietto	P38
		Buenos Aires, Argentina	
11	Ospizio Soldi	P40	
	Cremona, Italy		
HOTEL	12	Hilton Hotel	P42
		Istanbul, Turkey	
13	Hilton Hotel Manchester	P46	
	Manchester, UK		
STADIUM	14	Nelson Mandela Bay Stadium	P48
		Port Elizabeth, South Africa	
15	Green Point Stadium	P49	
	Cape Town, South Africa		
APARTMENT	16	Akasya Residence	P50
	Istanbul, Turkey		
TRAINING CENTER	17	Daikin Ales Aoya Global Training Center	P52
	Tottori, Japan		
COMPLEX	18	Shangyu Baiguan Building	P54
		Shangyu, China	
	19	Hengze Tiancheng	P56
	Dalian, China		
20	Umeda Hankyu Building	P58	
	Osaka, Japan		

1

São Paulo, Brazil

Banco Santander S.A.

PROJECT OUTLINE

Location	São Paulo, Brazil
Application	Office
Number of floors	31F
Project year	2009
Total floor area	101,458 m ²

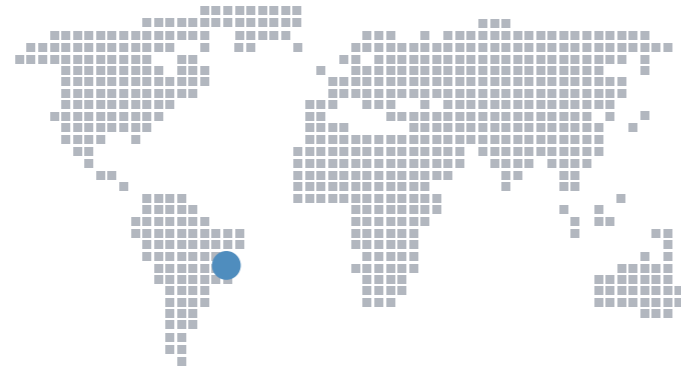

EQUIPMENT

Outside unit	Indoor unit	Others
RWEYQ10M × 9	FXSQ-20 × 29	FXSQ-63 × 159
RWEYQ20M × 9	FXSQ-25 × 2	FXSQ-80 × 94
RWEYQ30M × 44	FXSQ-32 × 91	FXSQ-100 × 61
	FXSQ-40 × 50	FXSQ-125 × 944
	FXSQ-50 × 10	FXSQ-250 × 2
		Control system:
		IPU'S × 9
		Interface for BACnet® × 9

PROJECT COMMENTARY

The Santander Tower is a worldwide reference of high technology allied with Green Building Certification. With its high energetic efficient system, it attends the LEED Certification.

It's the first undertaking in Latin America that uses a Water-cooled VRV system, with 4,450 HP capacity. With its hybrid design and flexible installation, each zone has its own temperature control. The microprocessed system allied to a high technology software allows the remote control of the system by the Building Automation System.

DESIGN DRAWING

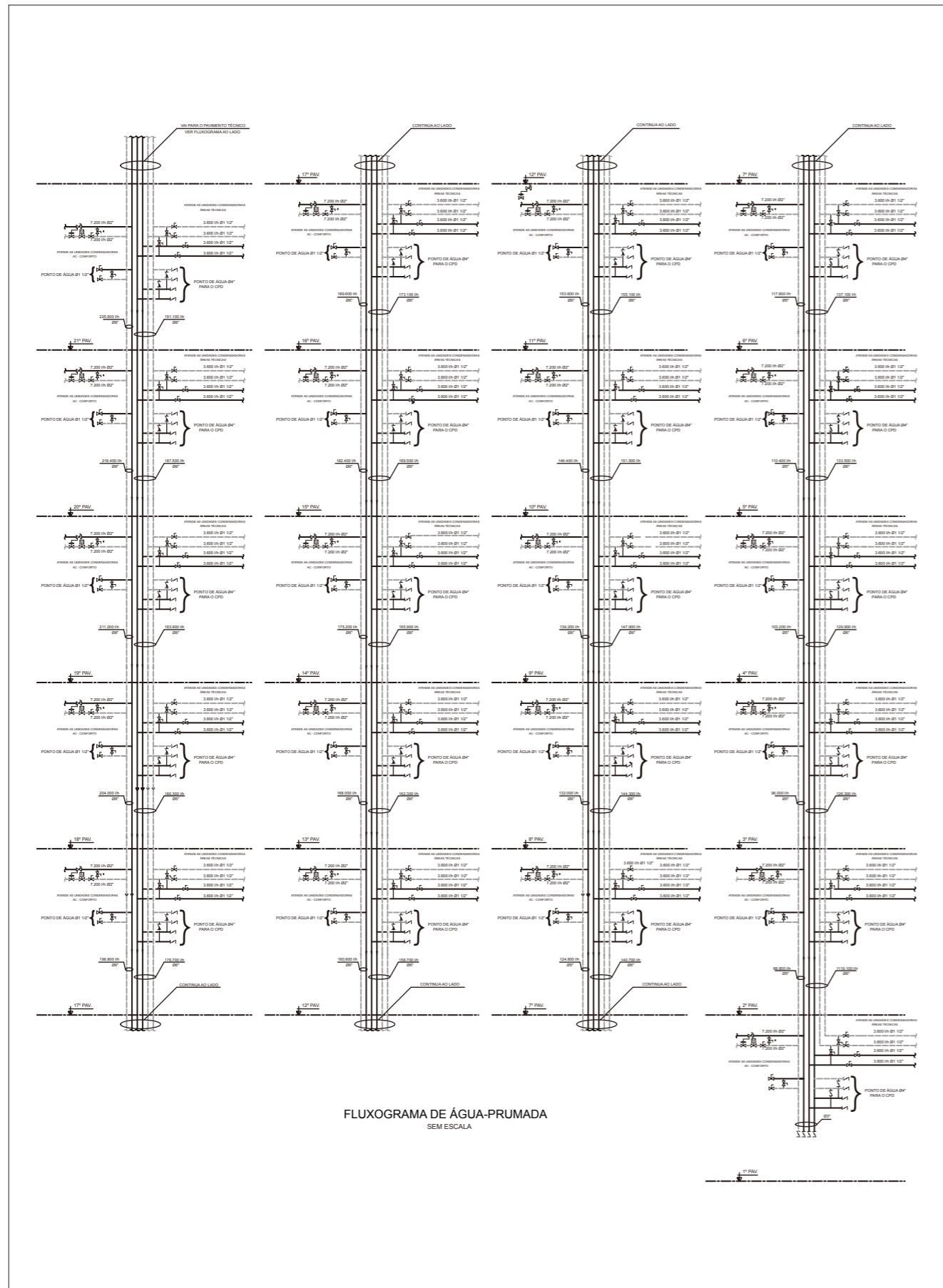

Fig-1 Piping Diagram

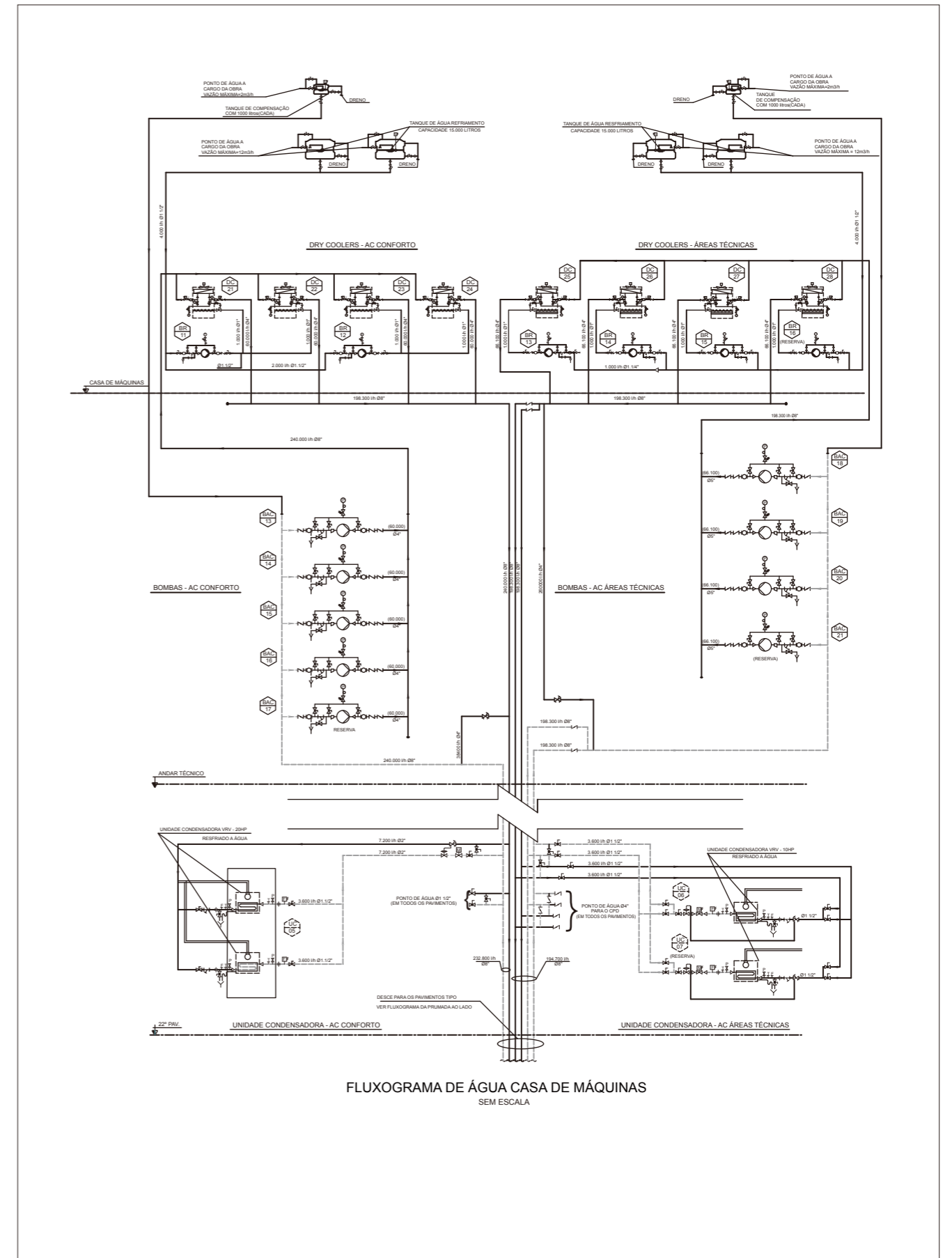

Fig-2 Piping Diagram

2 Beijing, China News Plaza

PROJECT OUTLINE

Location	Beijing, China
Application	Office
Number of floors	20F
Project year	2009
Total floor area	125,000 m ²



DESIGN DRAWING

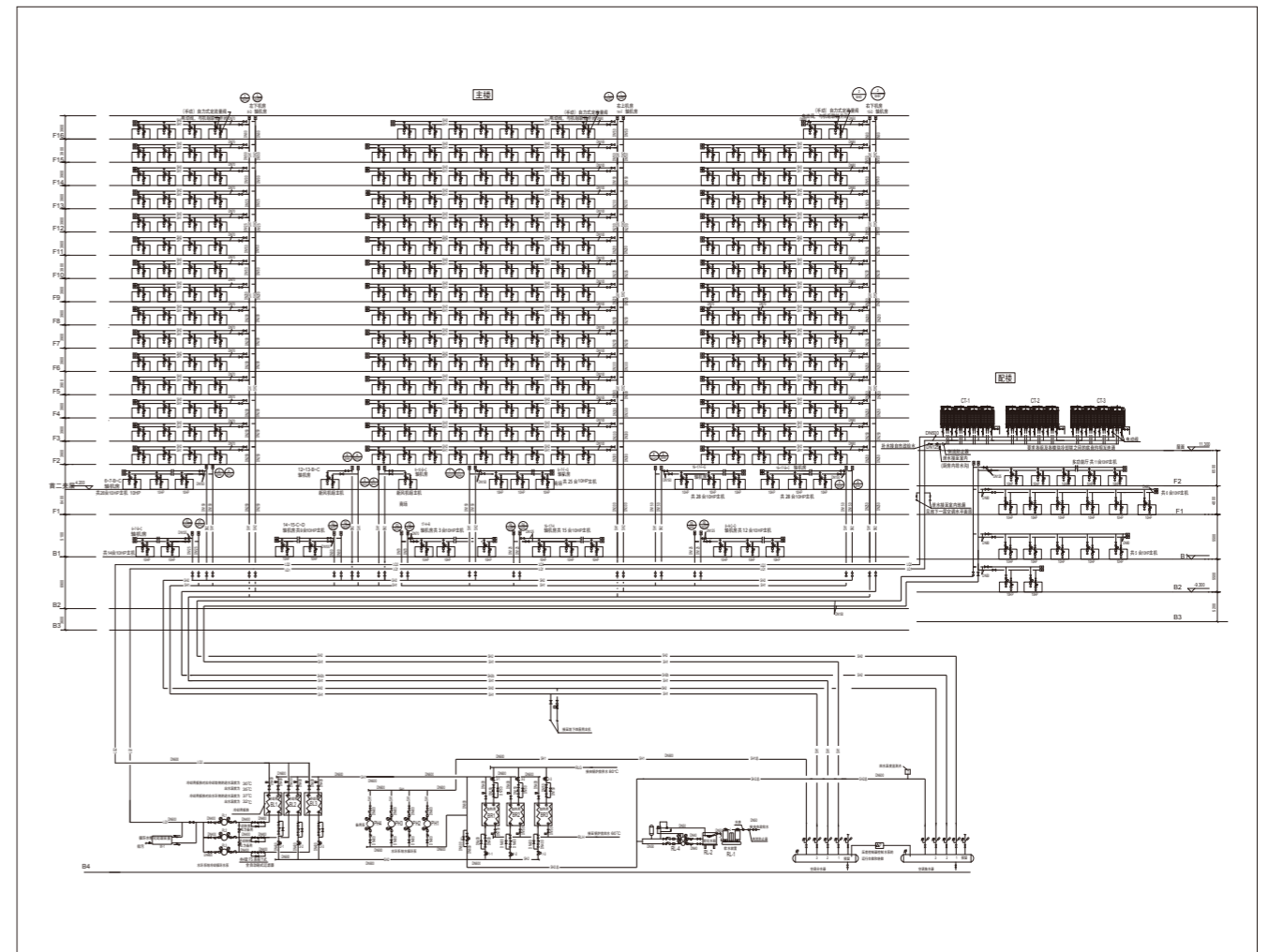

Fig-1 Piping Schematic Diagram

EQUIPMENT

Outside unit	Indoor unit	Others
RWEYQ10M × 14 RWEYQ20M × 53 RWEYQ30M × 85	FXSQ × 1,729 FXDQ	Control system: intelligent Manager Interface for BACnet® × 9

PROJECT COMMENTARY

Followings are reasons to install water cooled VRV system for this project.

1. Individual operation is necessary because foreign newspaper medias will be tenants.
2. There is no place for the outdoor units of air cooled VRV.
3. The owner of the building prefer new technology.

Heat source in winter is gas boiler for this building.

3 Pune, India Kirloskar Brothers Ltd.

PROJECT OUTLINE

Location Pune, India
 Application Office
 Number of floors 4F
 Project year 2009
 Total floor area 11,600m²

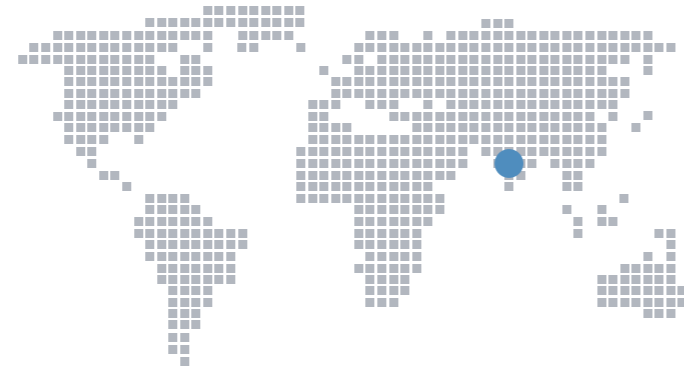

EQUIPMENT

Outside unit	Indoor unit	Others
RWEYQ10MY1 × 2	FXFQ25PVE × 50	AC unit
RWEYQ20MY1 × 5	FXFQ32PVE × 40	Split System × 4
RWEYQ30MY1 × 18	FXFQ40PVE × 60	Control System
RXYQ12PAY6 × 1	FXFQ50PVE × 23	intelligent touch Controller × 4
RXYQ16PAY6 × 2	FXFQ63PVE × 14	Interface for use in BACnet® × 1
	FXFQ80PVE × 9	
	FXFQ100PVE × 3	
	FXFQ125PVE × 2	
	FXDQ25PBVE × 3	
	FXDQ50NAVE × 5	
	FXDQ63NBVE × 6	
	FXMQ40PVE × 1	
	FXMQ80PVE × 2	
	FXMQ100PVE × 1	
	FXMQ125PVE × 2	
	FXMQ200MAVE × 14	
	FXMQ250MAVE × 10	
	FXAQ32MAVE × 10	
	FVYCP450MR × 2	

DESIGN DRAWING

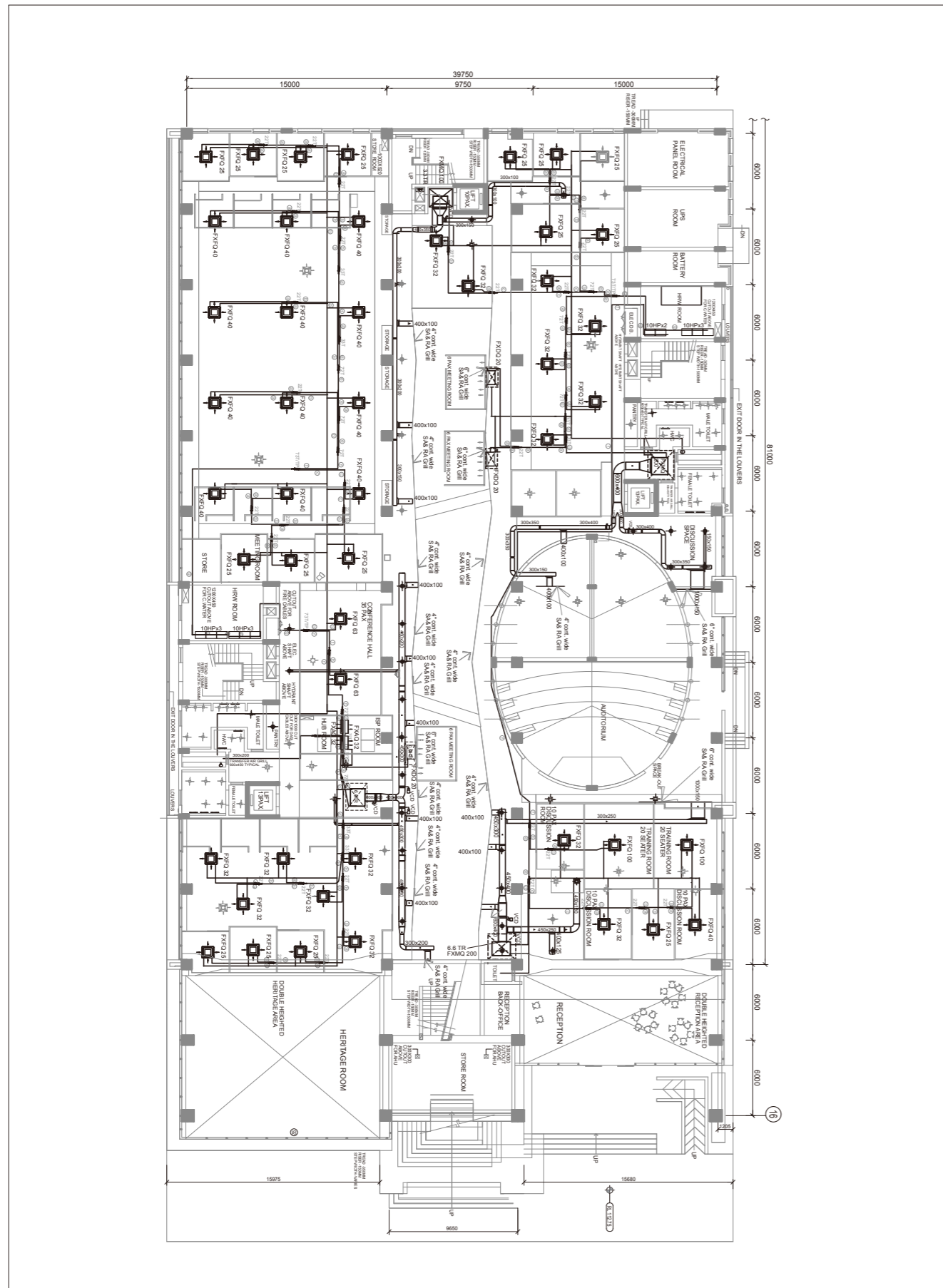

Fig-1 Ground Floor Plan

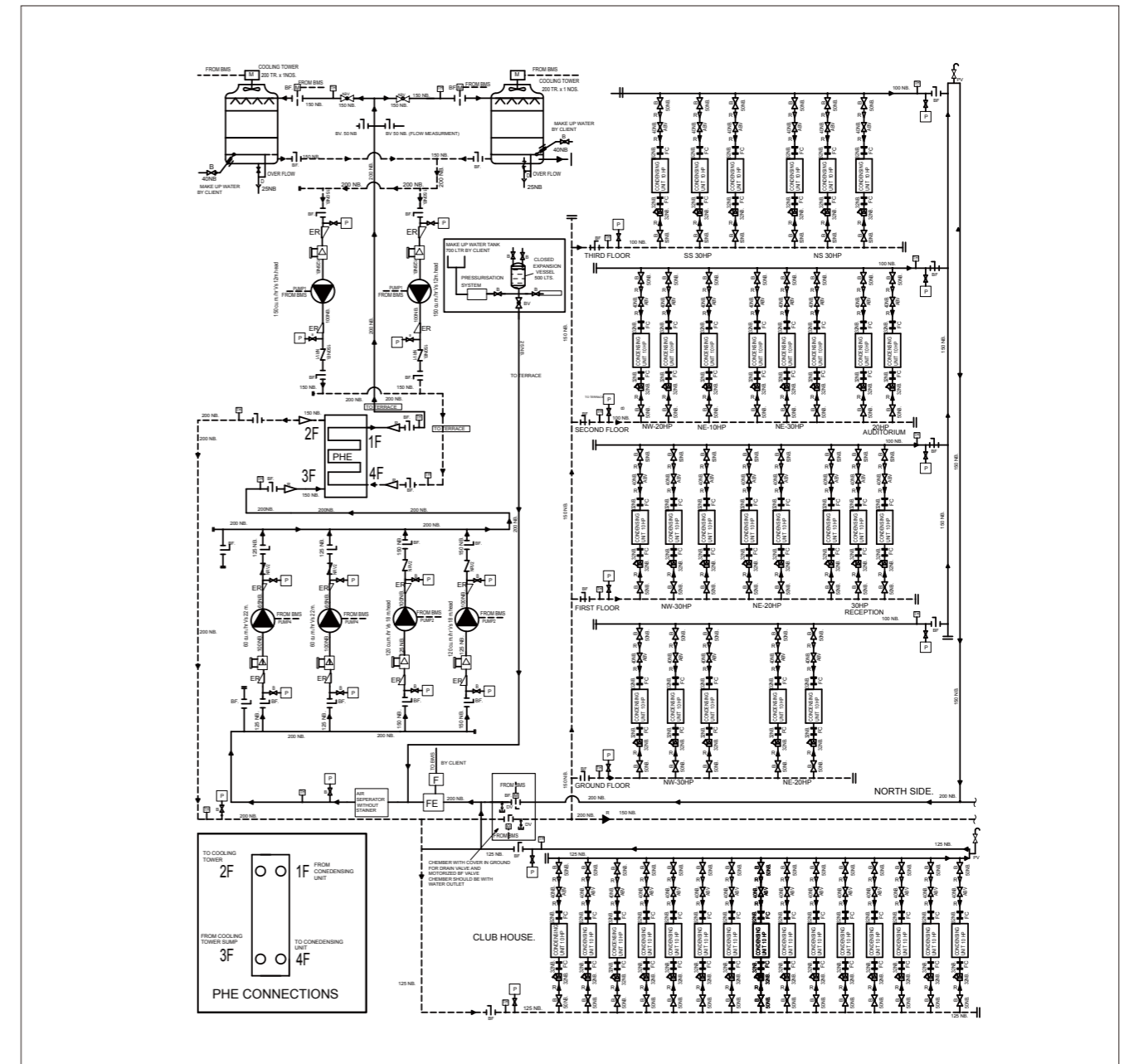

Fig-2 Water Piping Diagram

PROJECT COMMENTARY

Customer was keen to use emerging new technology, at the same time planning for LEED Platinum Rated Building. Water Cooled-VRV system was selected due to its important feature - high COP which means lower running cost and some other key unique features like wide variety of indoor units, low noise level, smaller external footprint of the units, high energy efficient system & control system is provided via interface through Bacnet gateway to the building automation system.

This office building is India's first WC-VRV system & Certified as " **LEED PLATINUM RATED BUILDING** " by Indian Green Building Council. Consultant have opted for WC-VRV system because of its energy saving feature, high reliability, high efficiency & Environmental friendliness (R410A Refrigerant).



4 Pune, India SUZLON Energy Ltd.

PROJECT OUTLINE

Location Pune, India
 Application Office
 Number of floors 4F
 Project year 2009
 Total floor area 24,980m²

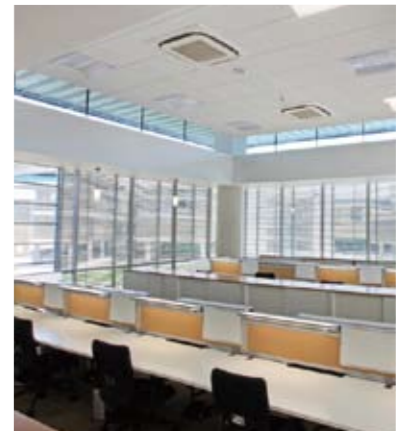
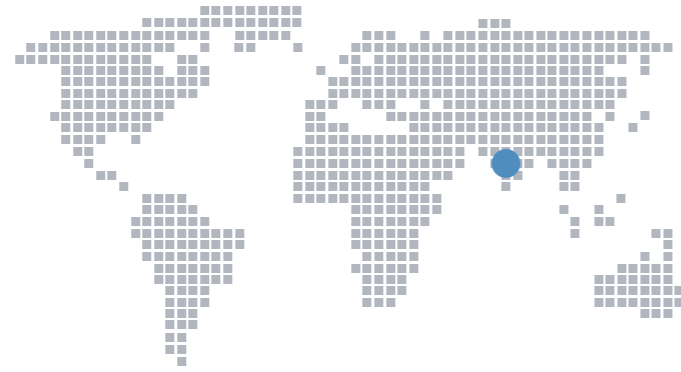

EQUIPMENT

Outdoor unit		Indoor unit		Others
RWEYQ30MY1 × 17	RXYMQ5PVE × 1	FXFQ32PVE × 28	FXDQ20PBVE × 85	AC unit Split System × 4 SkyAir × 3
RWEYQ20MY1 × 33	RXYQ5PAY6 × 3	FXFQ40PVE × 9	FXDQ25PBVE × 63	
RWEYQ10MY1 × 4	RXYQ8PAY6 × 5	FXFQ50PVE × 55	FXDQ32PBVE × 45	
	RXYQ12PAY6 × 1	FXFQ63PVE × 67	FXDQ40NBVE × 47	Control System intelligent Manager III × 4 Interface for use in BACnet® × 1
	RXYQ16PAY6 × 5	FXFQ80PVE × 78	FXDQ50NBVE × 40	
	RXYQ18PAY6 × 2	FXFQ100PVE × 52	FXDQ63NBVE × 12	
	RXYQ36PAY6 × 1	FXFQ125PVE × 29	FXAQ25MAVE × 3	
		FXMQ100PVE × 23	FXAQ32MAVE × 8	
		FXMQ80PVE × 3	FXAQ40MAVE × 2	
		FXMQ125PVE × 7	FXAQ50MAVE × 1	
		FXMQ200MAVE × 8	FXAQ63MAVE × 30	
		FXMQ250MAVE × 7		

DESIGN DRAWING

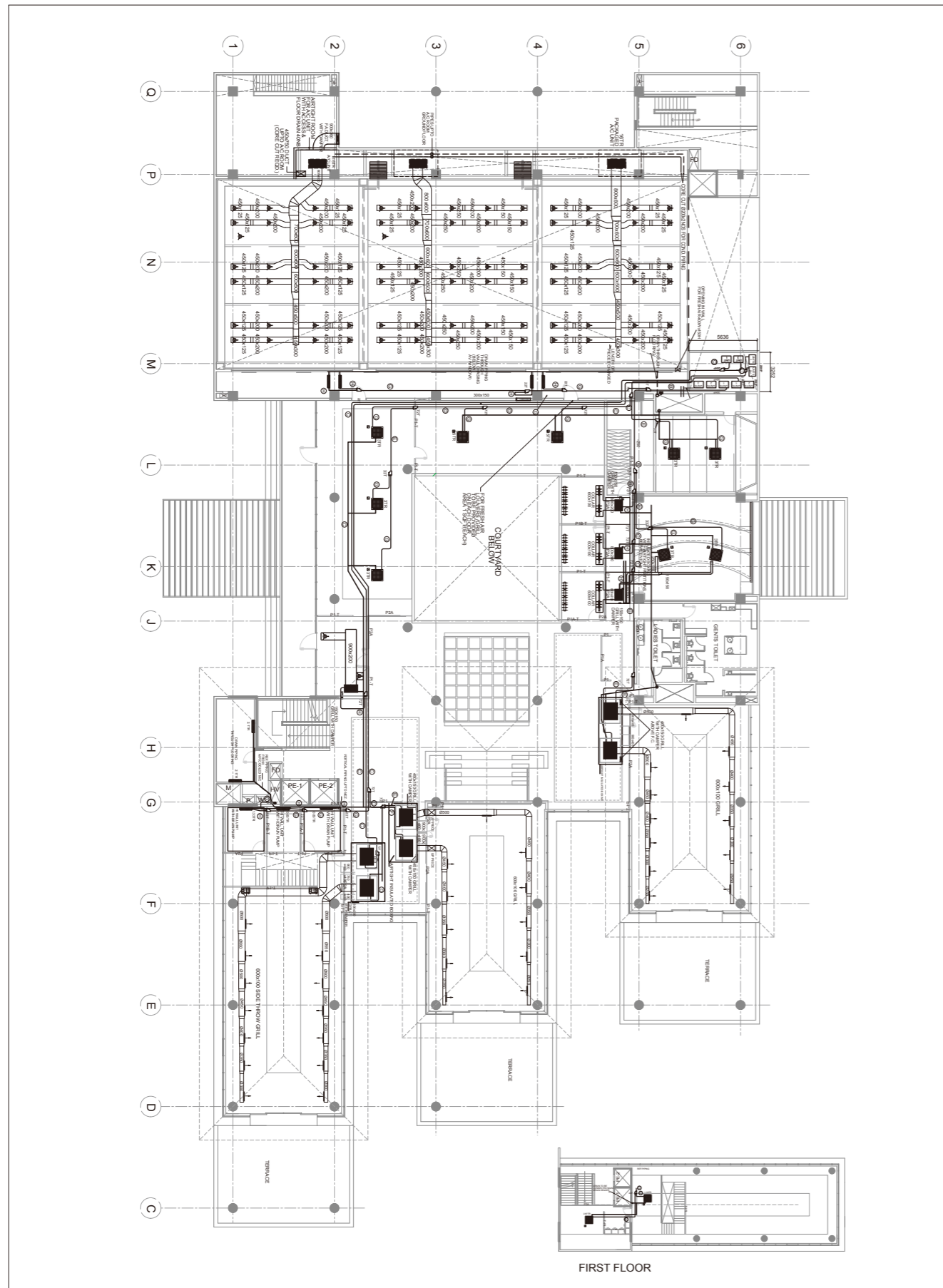

Fig-1 Design Drawing, Piping Drawing Indoor Unit and Outside Unit Location

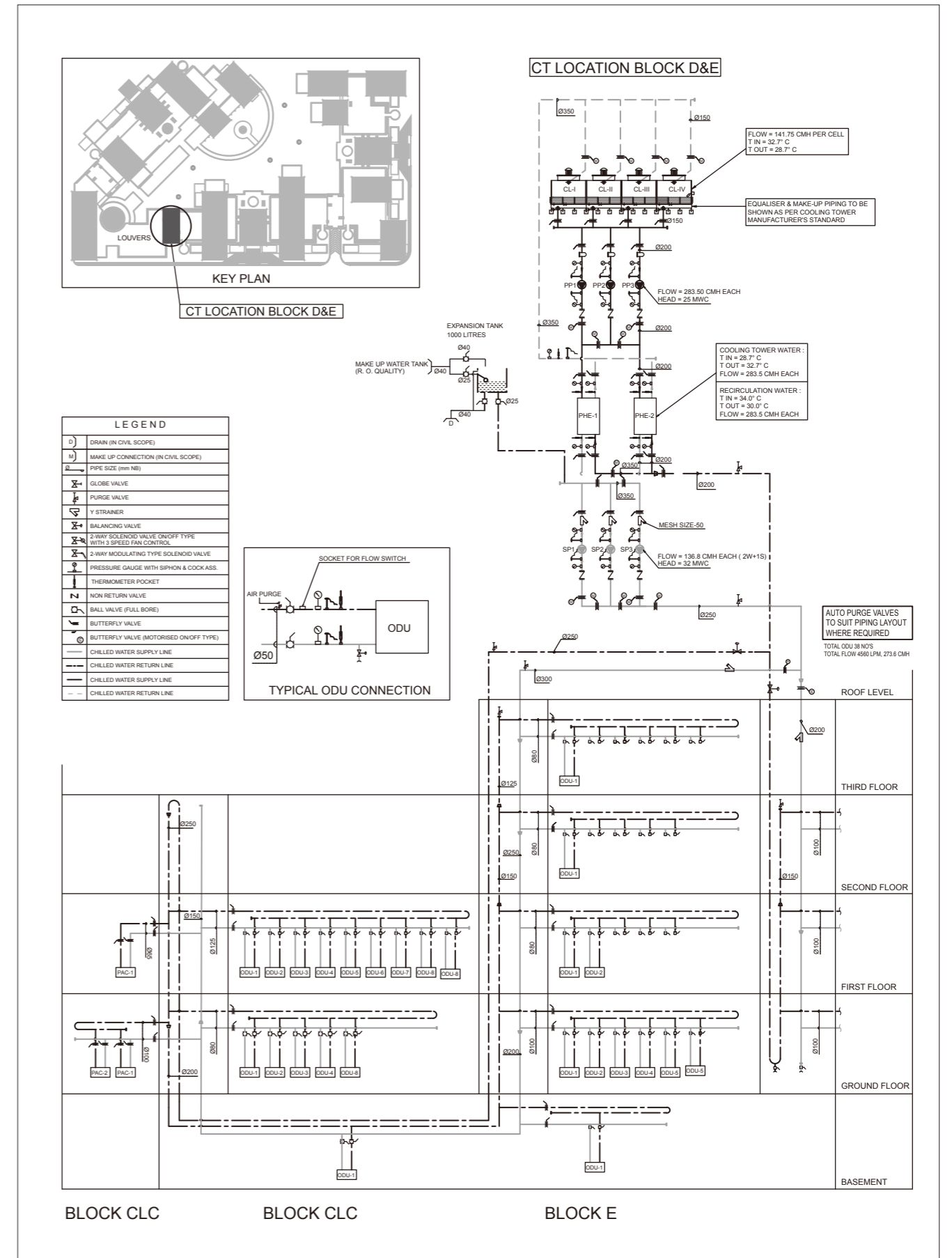

Fig-2 Cooling Water Diagram

DESIGN DRAWING

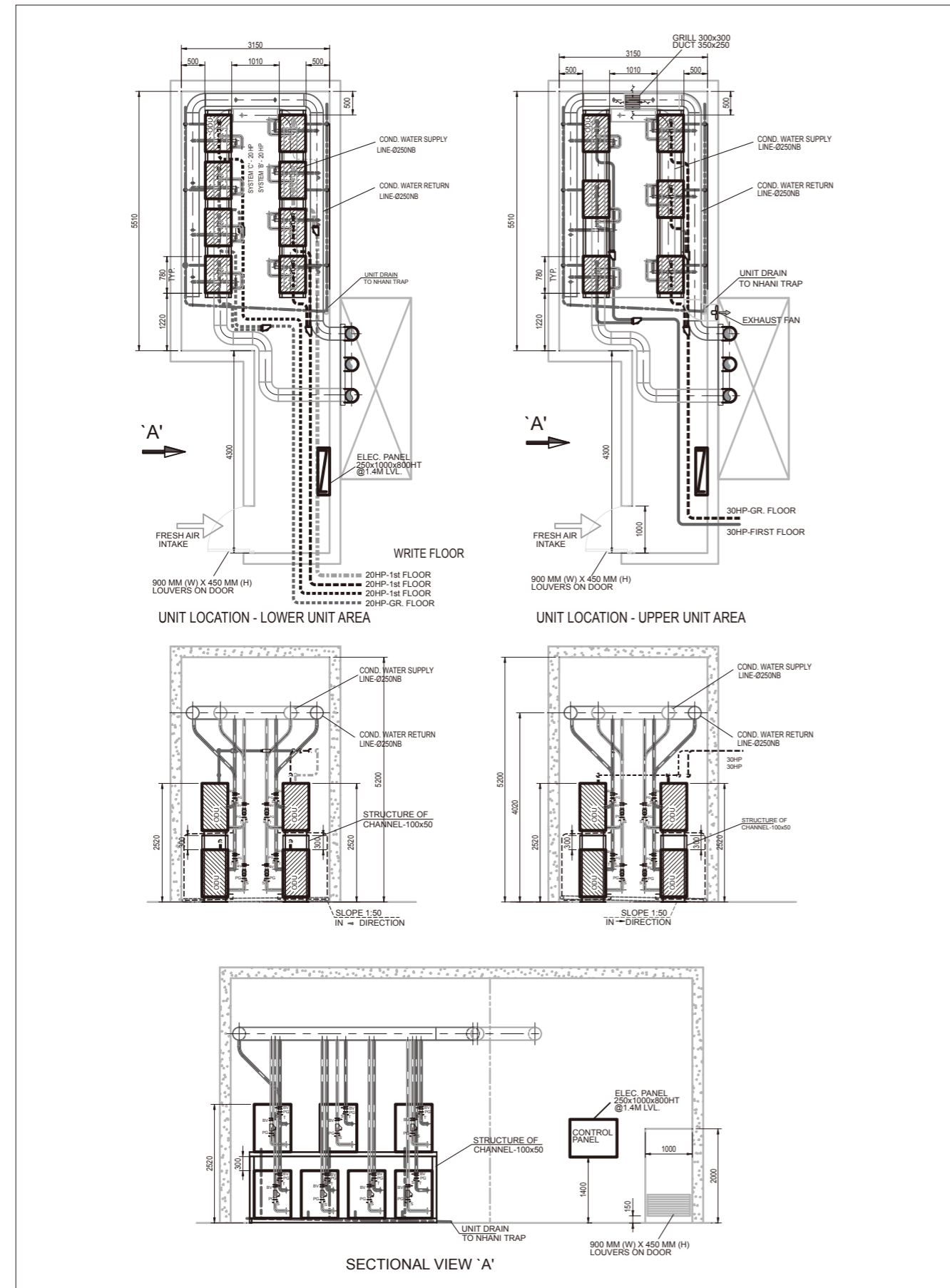

Fig-3 Outside Unit Location

PROJECT COMMENTARY

Suzlon Energy is a global wind power company based in India. Suzlon Market Share worldwide (Combined with Repower) is 8% thereby making Suzlon the 5th largest wind turbine manufacturing group in the world.

Water Cooled-VRV system was selected due to its important feature - high COP and other key unique features like wide variety of indoor units, low noise level, smaller external footprint of the units. Also this Office building is separated in blocks, and it was difficult by using Central air-conditioning system (Chiller) to accommodate bulky units & running chilled water piping in space available for installation.

This office building is also being planned as a Green Building project installed with WC-VRV system and this project is being prepared for "LEED RATING" certification.

Consultant have opted for WC-VRV system because of its energy saving feature, high reliability and high efficiency.

5 Osaka, Japan Hommachi Minami Garden City

PROJECT OUTLINE

Location Osaka, Japan
 Application Office
 Number of floors 26F + B2F
 Project year 2011
 Total floor area 46,820.3 m²



EQUIPMENT

Outside unit

RWEYP280A x 72
 RWEYP224A x 10

Indoor unit

FXYP112A x 6
 FXYP90A x 65
 FXYP71A x 66
 FXYP56A x 91
 FXYP45A x 23
 FXYSP36M x 22

Others

Total heat exchanger
 VAM800 x 8
 VAM500 x 11

DESIGN DRAWING

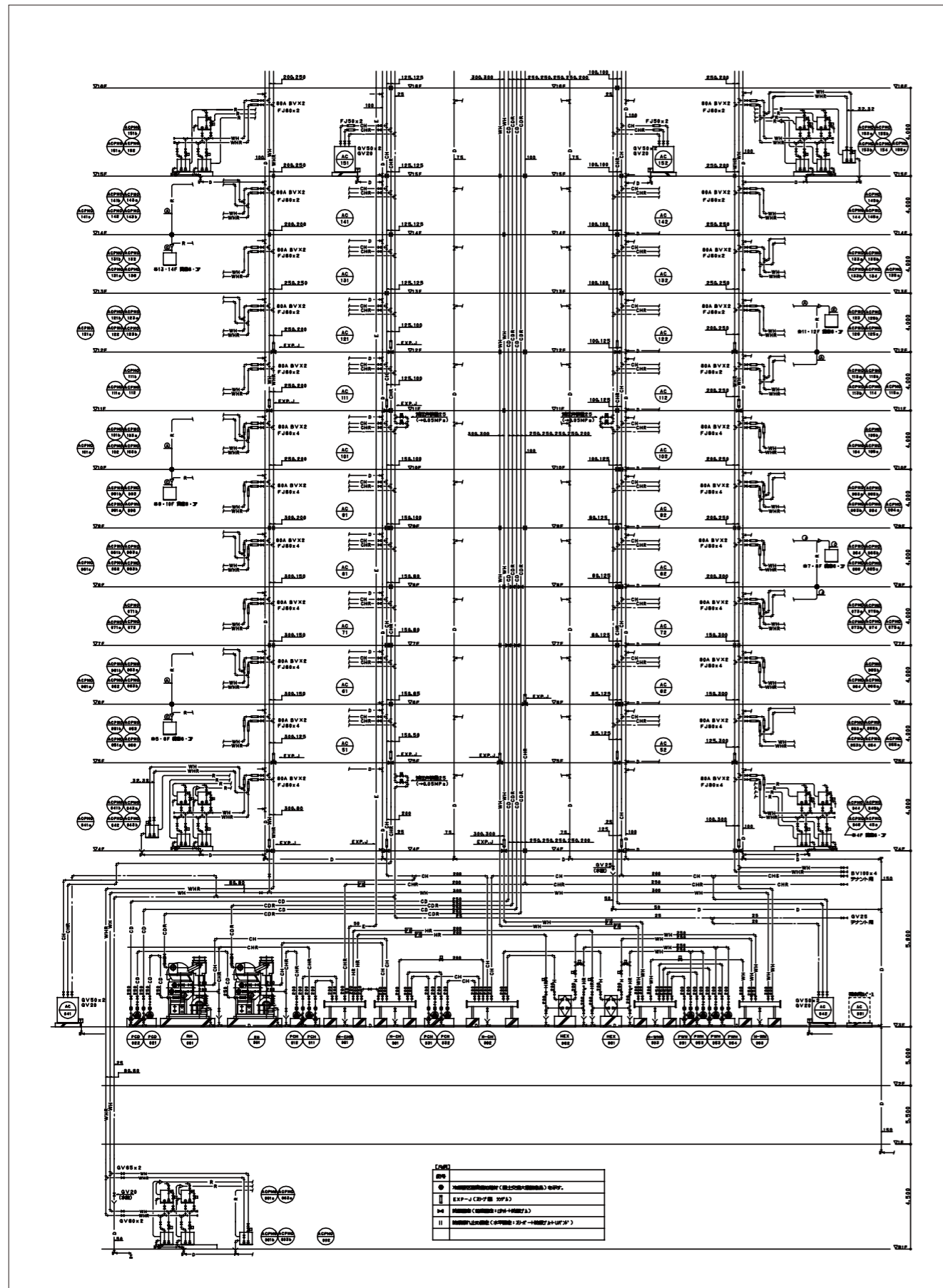

Fig-1 Piping Diagram for Heating Source by Absorption Chiller

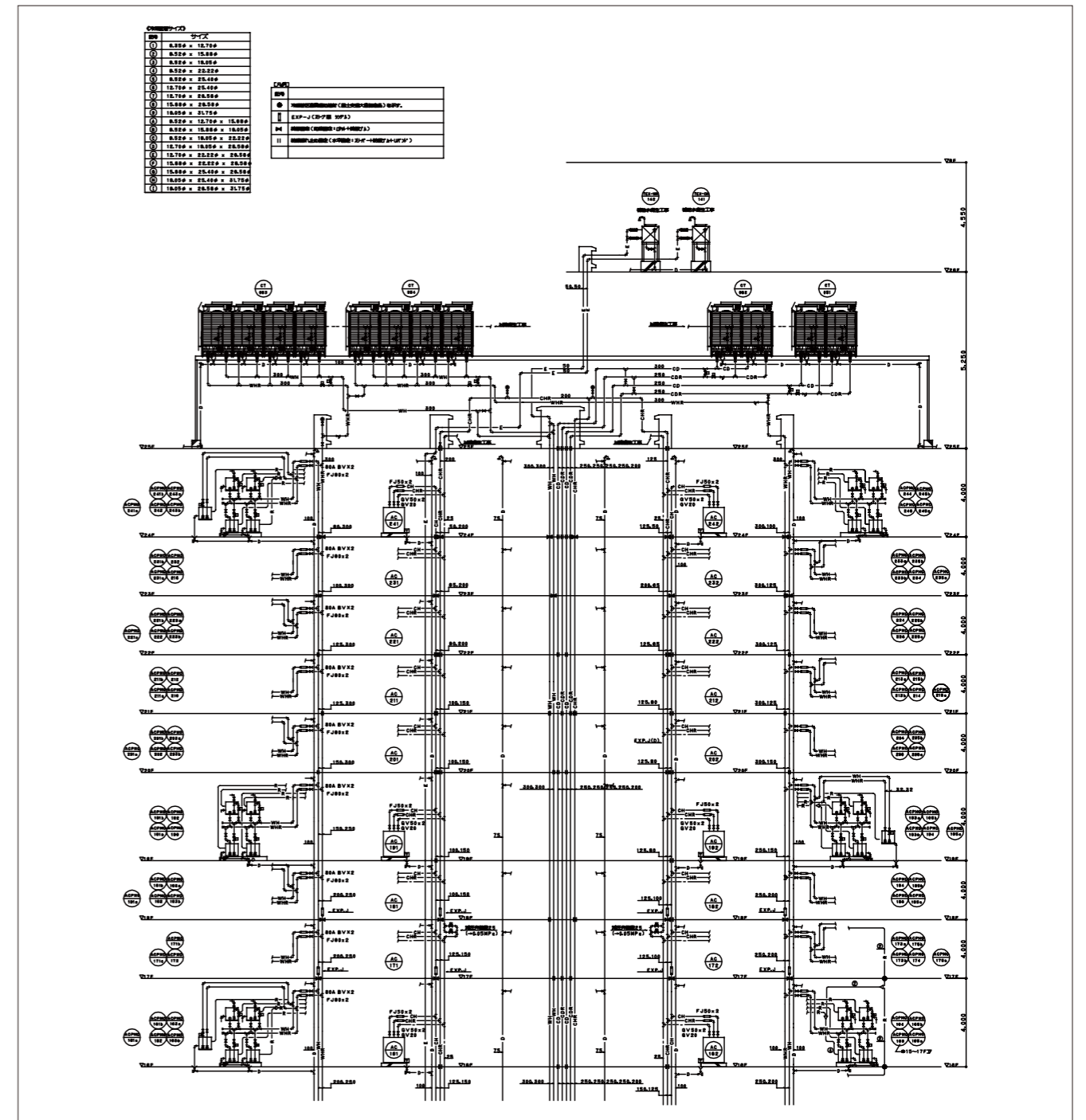

Fig-2 Piping Diagram for VRV Will

PROJECT COMMENTARY

Air-cooled package system is used for 1st floor entrance lobby. 4th floor to 24th floor office area is air-conditioned by water-cooled VRV system. The reasons why water-cooled VRV is selected for this building are as follows.

There are 4 requests from owner. First request is individual control since this building is tenant office building and working time of each tenant is different.

Second reason is installation space. This building applies glass exterior design and there is no space for air-cooled outdoor units to be installed. Third reason is long piping length for high raised building. Last one is energy saving system.

Feature of water-cooled VRV matches these requests. All facility of this building (including air conditioning system) is controlled by BMS which is installed in control room of basement floor.

6

Almelo, Netherlands Magna Porta Almelo

PROJECT OUTLINE

Location	Almelo, Netherlands
Application	Office
Number of floors	14F
Project year	2007
Total floor area	5,130 m ²

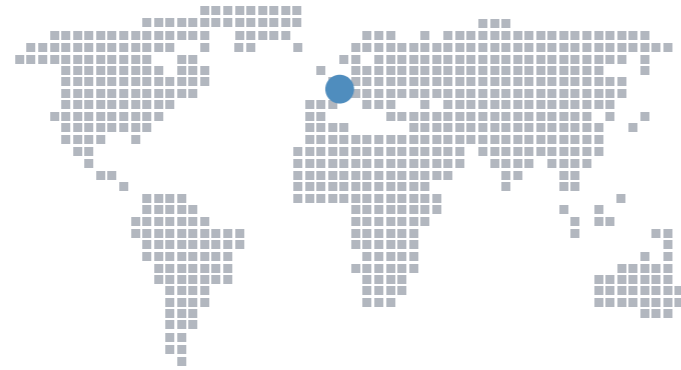

- EWWP065KAW
- Water cooled heatpump chiller
 - Refrigerant: R407C
 - Scroll compressor (2 x)
 - 75 kW



Floor heating on ground floor

EQUIPMENT

Outside unit

RWEYQ10 x 17

Indoor unit

Ground floor; FXZQ units
Other floors; FXSQ units

Others

EWWP065KAW
(Water cooled heatpump chiller)

Control system:
2 VKM units per floor
intelligent Manager

DESIGN DRAWING

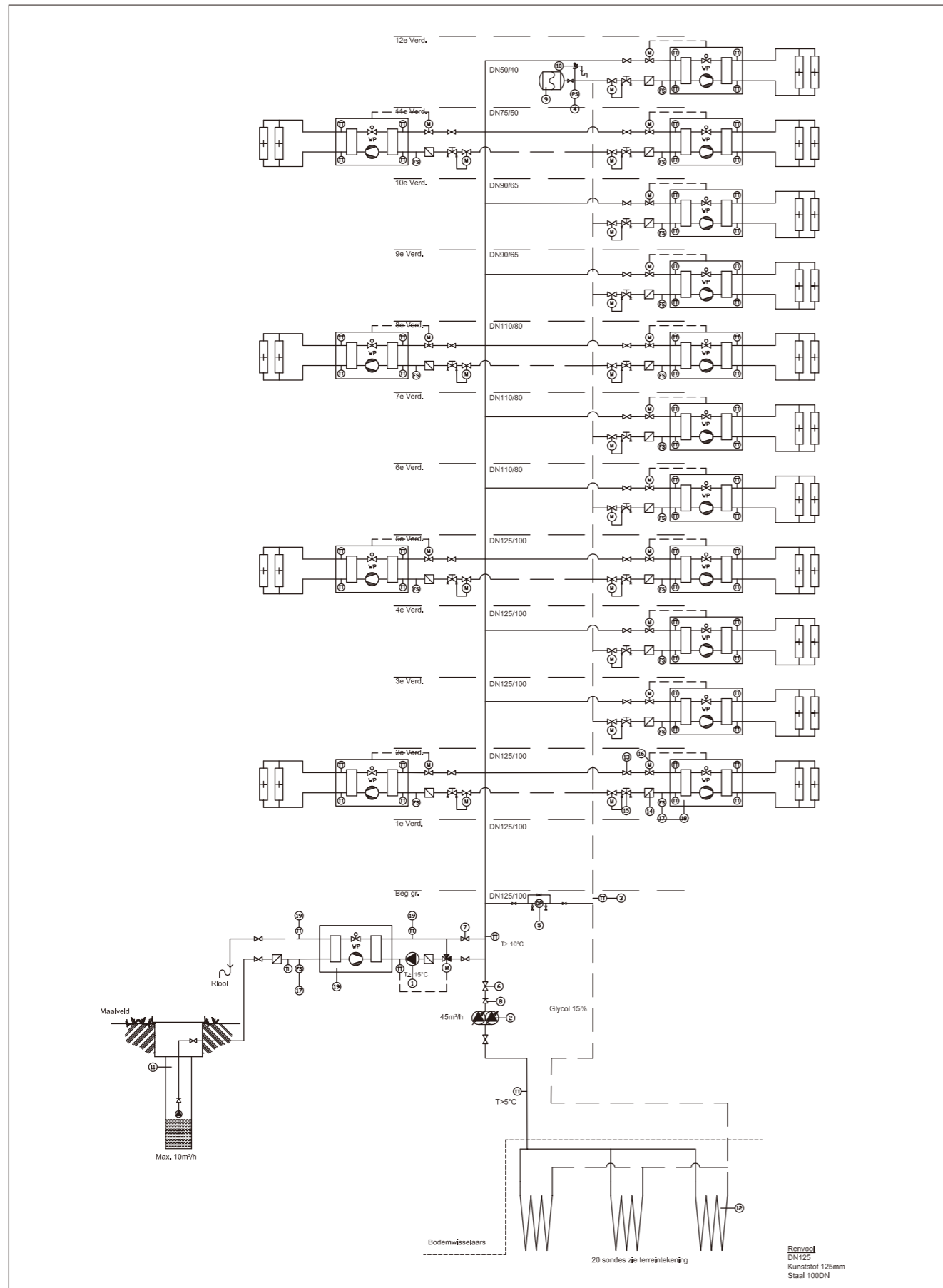

Fig-1 Piping Schematic Diagram

PROJECT COMMENTARY

This building is an unique building using geothermal heat. The dimension of the piping system in the ground are as follows; 75 meter long, 12 meter width and 40 meter (high) into the ground. 100 holes are drilled into the ground. Each room is individually controlled and simultaneous cooling and heating is possible by heat recovery system. Electricity consumption per tenant can be monitored by using kWh measurement and intelligent Manager system.

7 Groningen, Netherlands Ordina Groningen

PROJECT OUTLINE

Location Groningen, Netherlands
 Application Office
 Number of floors 4F
 Project year 2008

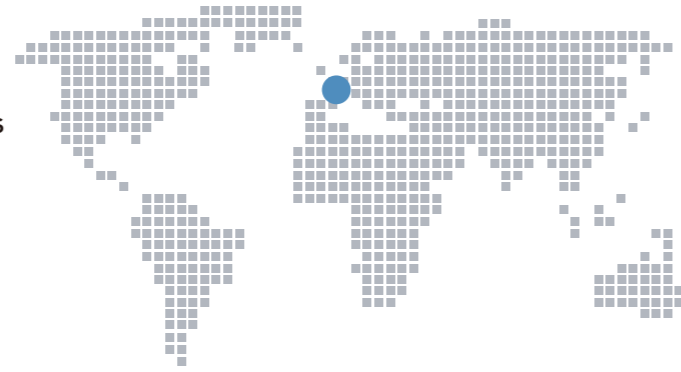

EQUIPMENT		
Outside unit	Indoor unit	Others
RWEYQ10 × 15	FXSQ × 130	Control system: intelligent Manager × 1

DESIGN DRAWING

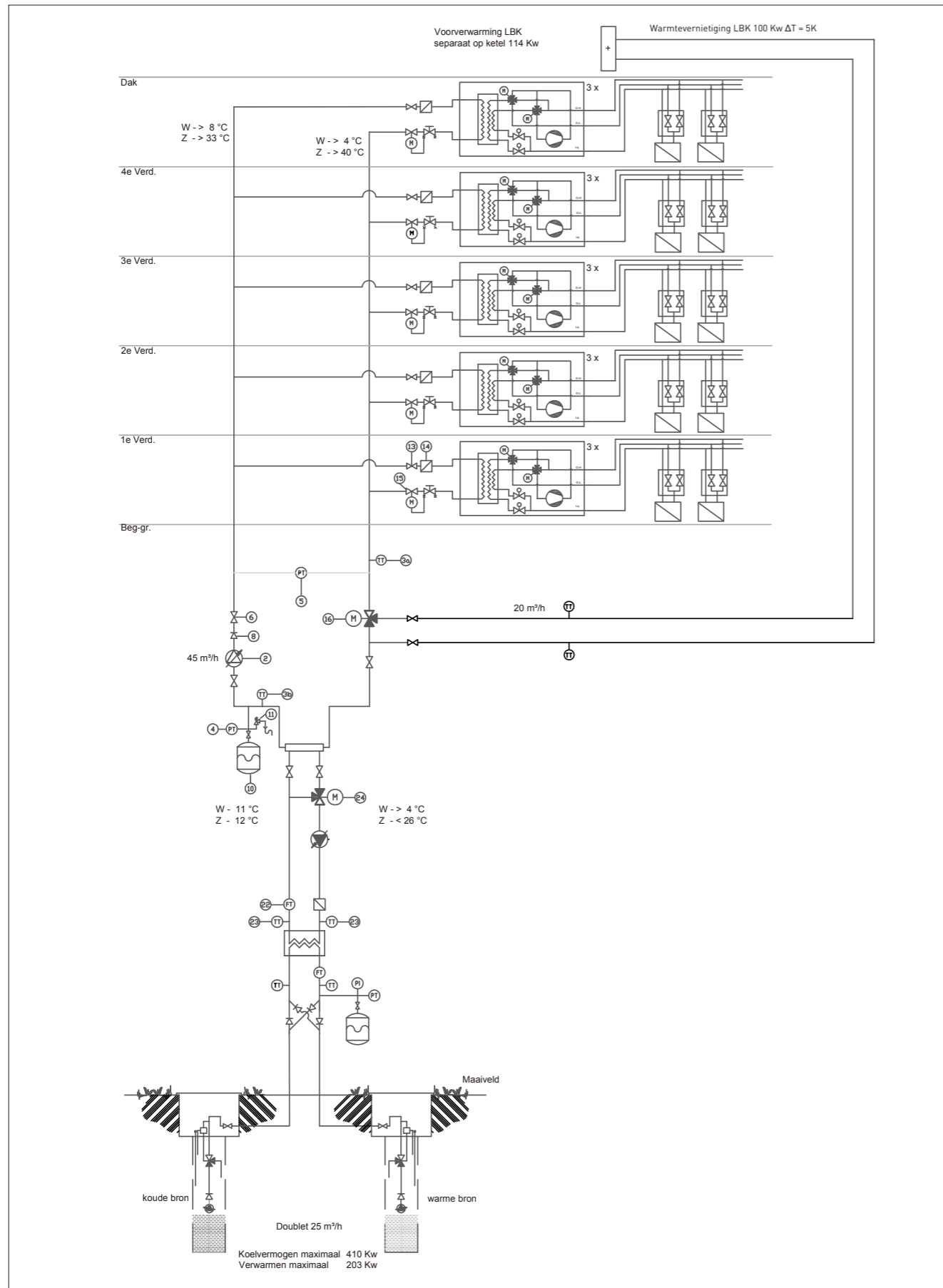

Fig-1 Schematic Diagram

PROJECT COMMENTARY

This building was originally designed with chiller and boiler system. Daikin Water cooled VRVIII heat pump connected to an open source is installed for refurbishment. Air handling unit is used for ventilation. Installation of water cooled VRV units are realised faster than planning. Each room is controlled by Intelligent Manager system.

8

Christchurch, New Zealand Clarendon Towers

PROJECT OUTLINE

Location Christchurch, New Zealand
 Application Office
 Number of floors 17F
 Project year 2010 Retrofit



DESIGN DRAWING

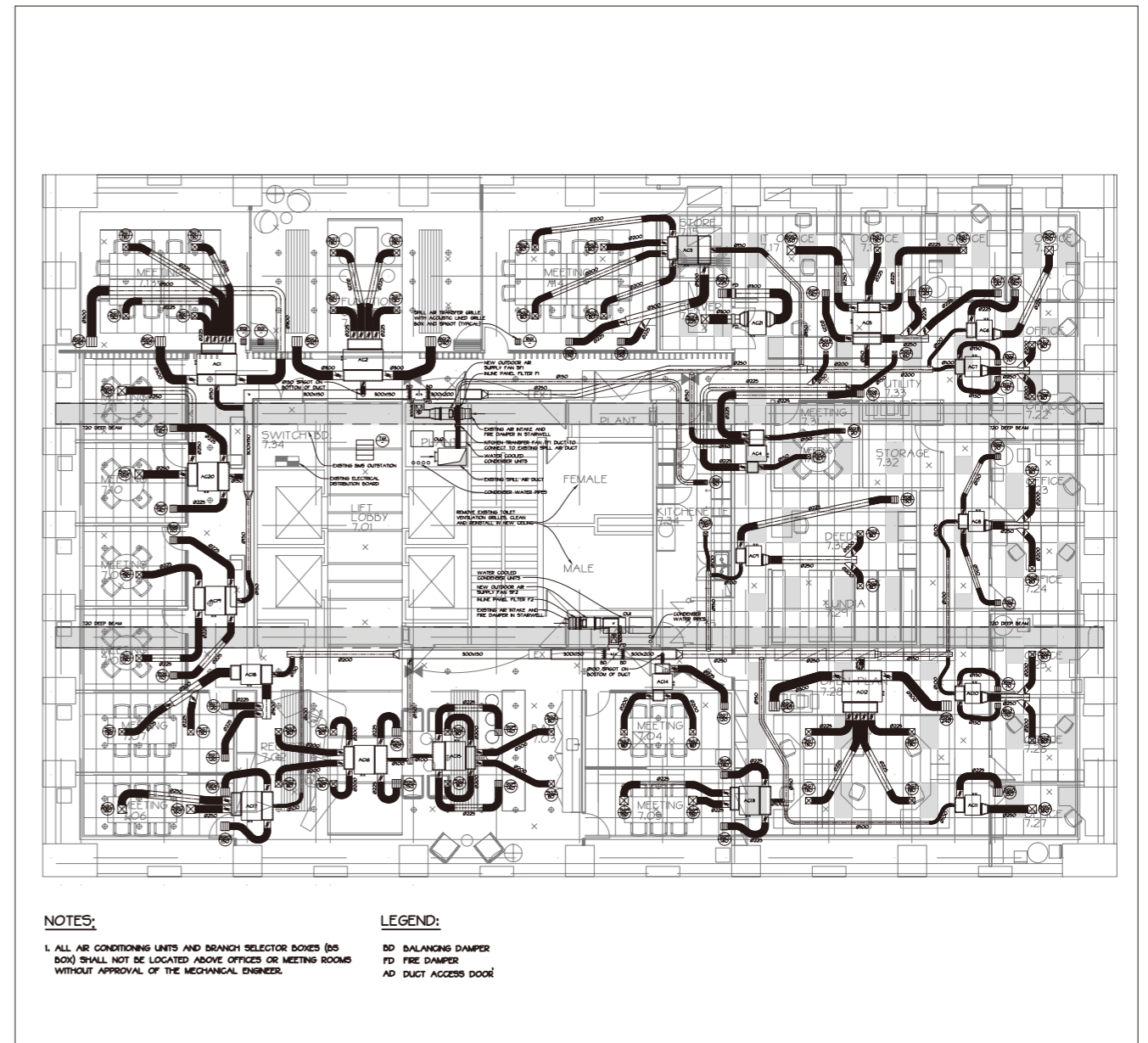

Fig-1 Floor Plan

EQUIPMENT

Outside unit

RWEYQ10 × 7

Indoor unit

FXMQ-PVE × 61

Others

BS Unit × 58
 intelligent Touch Controller

PROJECT COMMENTARY

Water-cooled VRV system was chosen instead of Air-cooled VRV due to limited space for condensers around the building. Condensers are installed in each floor. Existing hydronic circuit, pumps cooling towers were used for the project. System has demand cards per condenser set (6 in total). intelligent Touch Controller can control majority of system with BMS link to control water pumps / towers plus Di cards. Daikin was chosen because of high level of service during the initial design process.

9

Khartoum, Sudan

The NTC (National Telecom Corporation) Tower

PROJECT OUTLINE

Location	Khartoum, Sudan
Application	Office
Number of floors	29F
Project year	2008
Total floor area	32,000m ²

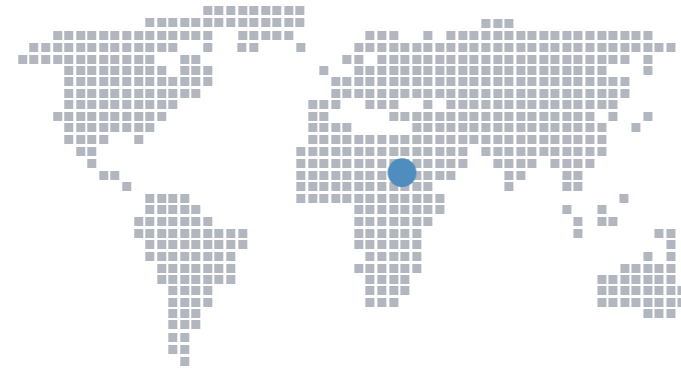

EQUIPMENT

Outside unit

235 units

Indoor unit

Cassette & Duct type x 473

PROJECT COMMENTARY

Water cooled VRV system is installed because of following reasons

1. Suitable for high raised building
2. Easy installation and maintenance
3. Energy saving. Energy consumption can be monitored by intelligent Manager.
4. High outdoor temperature (50°C in summer).

10 Buenos Aires, Argentina Hospital Finochietto

PROJECT OUTLINE

Location	Buenos Aires, Argentina
Application	Hospital
Number of floors	12F
Project year	2011
Total floor area	17,000 m ²

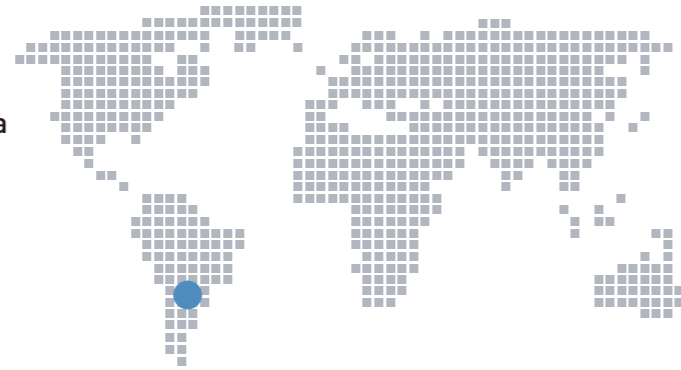

EQUIPMENT

Outside unit	Indoor unit	Others
RWEYQ8PY17 × 26	FXAQ20MAVE9 × 5	BRC1C62 × 297
RWEYQ10PY17 × 15	FXAQ25MAVE9 × 54	DCS601C51 × 4
RXYQ18PAY1 × 3	FXAQ40MAVE9 × 80	DMS502B51 × 2
RXYQ8PAY1 × 3	FXAQ63MAVE9 × 2	
RXYQ16PAY1 × 7	FXFQ25PVE9 × 5	BSV4Q100PV1 × 20
	FXFQ32PVE9 × 20	BSV6Q100PV1 × 12
	FXFQ40PVE9 × 12	BSVQ250PV13 × 3
	FXFQ50PVE9 × 1	BSVQ160PV13 × 5
	FXFQ80PVE9 × 3	BSVQ100PV13 × 6
	FXFQ63PVE9 × 16	
	FXMQ100PVE × 2	WGZ100D × 2
	FXMQ125PVE × 3	(Water cooled chiller)
	FXMQ250MAVE × 1	
	FXAQ32MAVE9 × 59	Control System:
	FXFQ125PVE9 × 2	Interface for use in BACnet® × 2
	FXMQ40PVE × 1	intelligent Touch Controller × 4
	FXFQ100PVE9 × 1	
	FXAQ50MAVE9 × 30	

PROJECT COMMENTARY

This project uses air-cooled VRV and water-cooled VRV system. Cooling tower, boiler and geothermal piping are equipped with this system. The energy saving system is used for this project in order to get the Green Building Certification.

Architects: Font-Alvarado-Sartorio
Thermomechanical company: Arq. Daniel E. Bourguignon & Asoc.

11 Cremona, Italy Ospizio Soldi

PROJECT OUTLINE

Location	Cremona, Italy
Application	Hospital
Number of floors	3F
Project year	2007
Total floor area	7,500 m ²

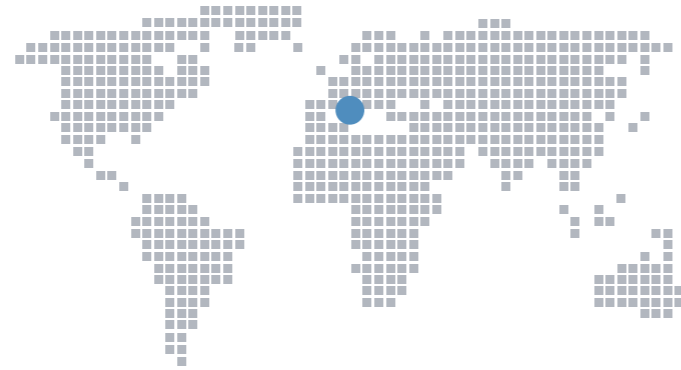

DESIGN DRAWING

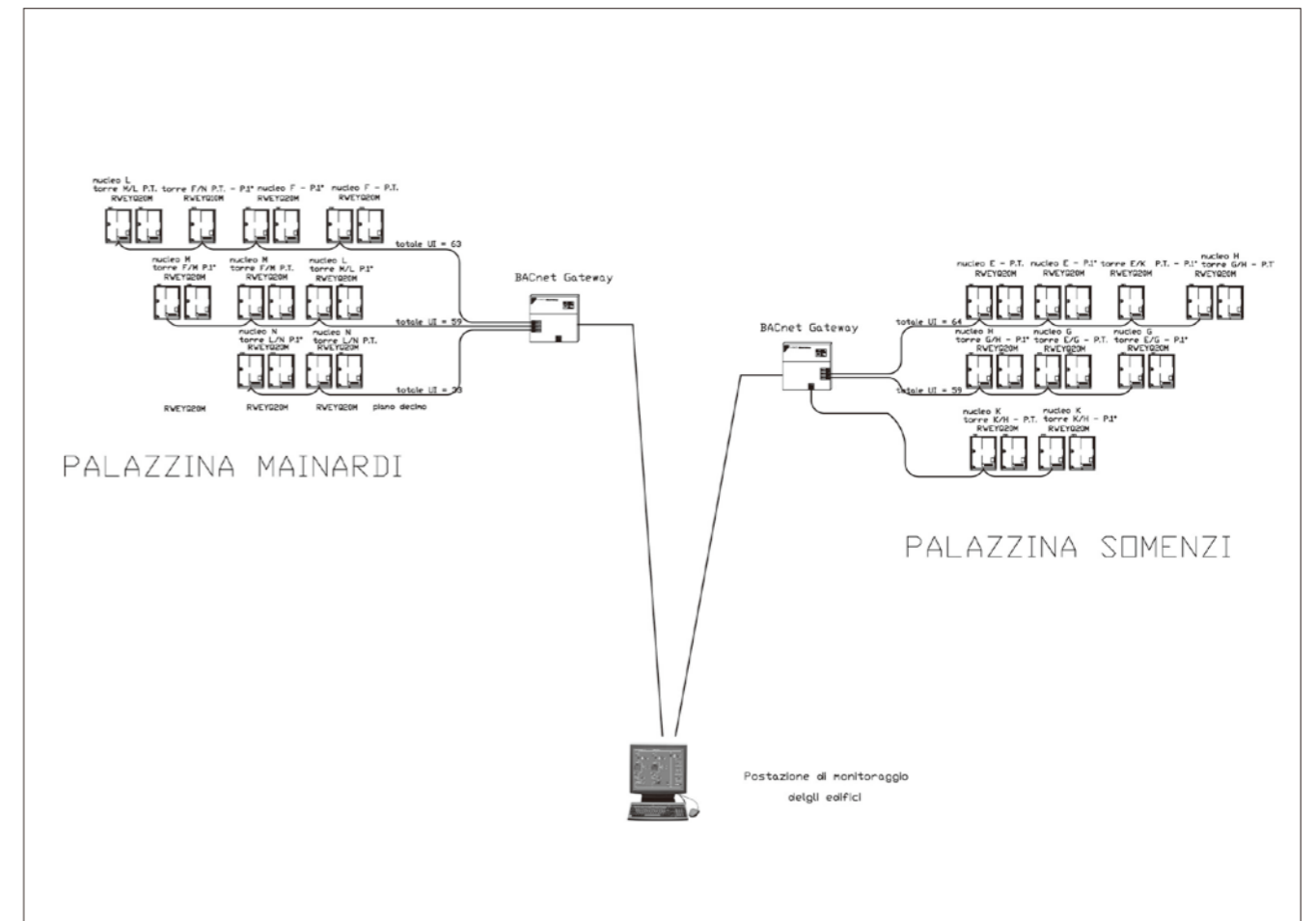

Fig-1 Wiring Diagram

EQUIPMENT

Outside unit	Indoor unit	Others
RWEYQ10M × 2	FXAQ20MA × 79	FXZQ20M8-G × 15
RWEYQ20M × 16	FXAQ25MA × 24	FXZQ25M8-G × 19
	FXAQ32MA × 88	FXZQ32M8-G × 4
	FXAQ40MA × 28	FXZQ40M8-G × 13
	FXAQ50MA × 29	FXZQ50M8-G × 6
	FXAQ63MA × 1	
		BRC7E618 × 249
		BRC7E530 × 62
		KHRQ22M29H × 61
		KHRQ22M64T × 38

PROJECT COMMENTARY

The air conditioning system for this rest home is a VRV VII system. The water is provided from a sink, with an immersion pump powering the circulating condensing circuit. The two buildings, Somenzi and Mainardi, have an extended area, and the system is installed on the third floor. There are outside units (VRV water cooled) in the basement (no air conditioning system), and on the ground and first floors. Installed power: 907 kW, Indoor units: wall mounted and concealed ceiling indoor units. One of the requests was to use spaces in the basement to install outside units, reducing the impact to the landscape of outside unit installation. Another important factor was its better energy efficiency, especially during the summer period. The rest home already had a heating plant, a burlap heating system (teleriscaldamento), and with the VRV system they also have a backup plant for the winter. And the fast installation that this system offered was important too. The installation was completed without inconveniencing the rest home guests. At this moment there is no centralized control system installed. Infrared remote controllers are used for regulation.

12

Istanbul, Turkey Hilton Hotel

PROJECT OUTLINE

Location	Istanbul, Turkey
Application	Hotel
Number of floors	25F
Project year	2012
Total floor area	29,000 m ²

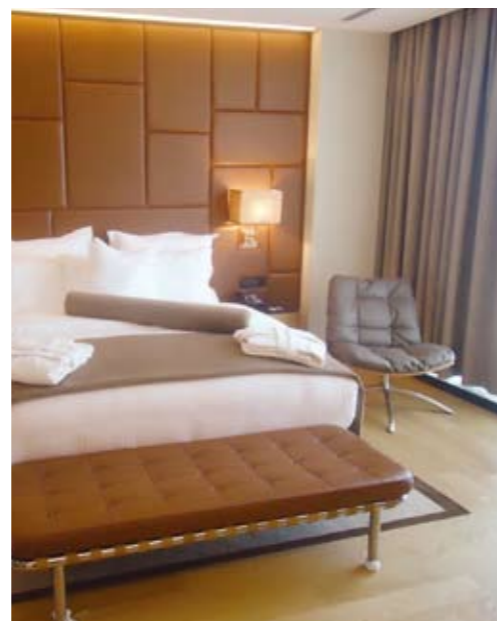
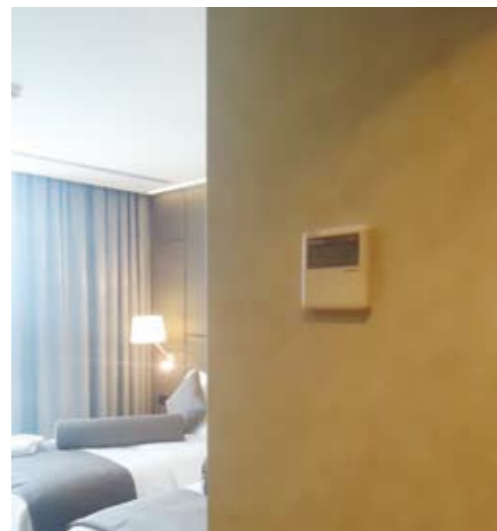
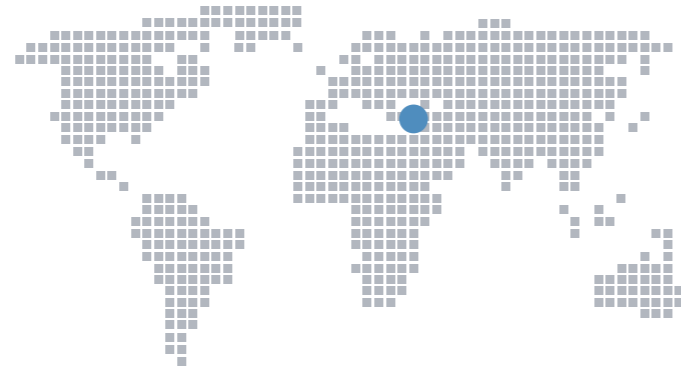

EQUIPMENT

Outside unit	Indoor unit		Others
RWEYQ8/10 x 135	FXSQ x 316	FXCQ x 9	Heat recovery BS unit
	FXDQ x 8	FXAQ x 6	BSVQ x 282
	FXMQ x 32	FXKQ x 2	HRV VKM100G x 23
	FXFQ x 10		BRC1D52 x 391
			intelligent Manager x 2

DESIGN DRAWING

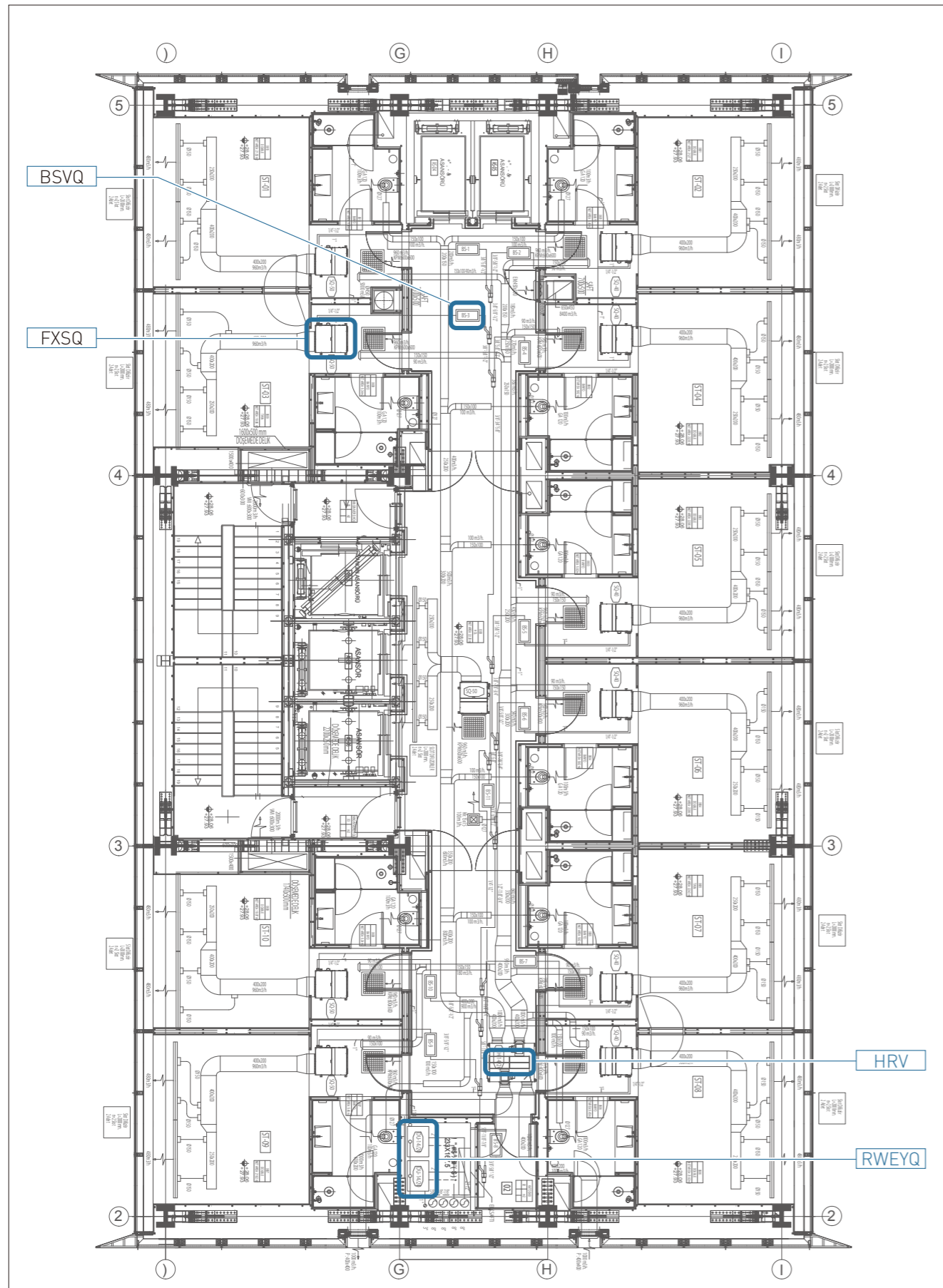

Fig-1 Floor Plan(7-12F)

PROJECT COMMENTARY

Daikin heat recovery water-cooled VRV system was installed instead of water-cooled chiller system. Outside units and heat reclaim ventilation indoor units are installed in each floor's mechanical room. There are following advantages of VRV system against water-cooled chiller system.

1. Total VRV outside units installation area for each floor is less than water-cooled chiller system installation area up to 50%.
2. VRV outside unit noise level (54 dBA) is lower than water-cooled chiller system (96 dBA).
3. VRV system power supply capacity is lower than 30% against water-cooled chiller system.
4. VRV system do not have start up current.
5. Energy saving with high COP value up to 50%.
6. VRV system needs less service people.
7. VRV system uses 20% lower boiler capacity for building's heating capacity.
8. There is no corrosion in piping when liquid flows because of non using water with fan coils.

13 Manchester, UK Hilton Hotel Manchester

PROJECT OUTLINE

Location	Manchester, UK
Application	Hotel
Number of floors	49F
Project year	2006

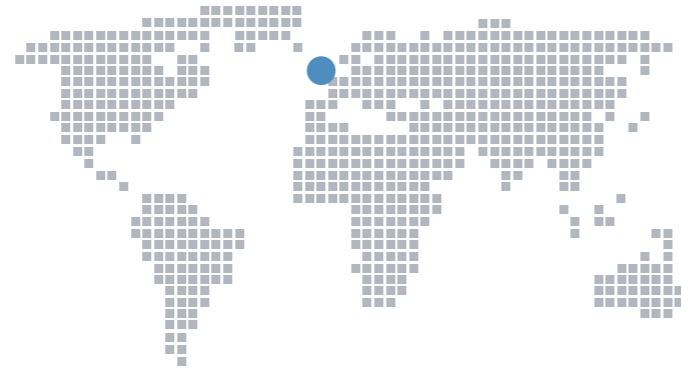

INDOOR UNIT INSTALLATION

This was a typical installation case for application in a hotel bedroom. As this was for residential and individual use, and not commercial use, higher specifications including good appearance, low sound, comfortable distribution and easy control were required.



Returning air intake for indoor unit is located above closet. Air passes across back wall and ceiling and reaches the unit. Grill is not located on ceiling in order to maintain an attractive appearance and to reduce cost.



A fresh air intake is located in the service space.

BS box is also installed in the service space. This equipment is covered with rubber material to decrease refrigerant flow sound.

Refrigerant detector is installed in lower corner of wall. When this sensor catches refrigerant, operation is stopped automatically.

EQUIPMENT

Outside unit	Indoor unit	Others
RWEYQ10 × 35	FXDQ20/25 × 290	BRC2A51

PROJECT COMMENTARY

A Daikin water-cooled VRV-WII air conditioning system was selected for this project over a conventional chiller/ LPHW-based 4 pipe fan coil system. The fan coil system did not meet Part 'L' carbon emission requirements and would have required a major redesign of the building. Also, the VRV-WII system provides the client with the added benefit of an enhanced capital allowance and its attendant savings in capital outlay.

System control is provided via simplified room controllers interfaced through a LON gateway to the hotel's 'Fidelio' booking system. Three operating modes are available—'room not booked/unoccupied' with a wide band of control between 18 and 28°C; 'room booked' with a band width of 16 to 26°C; and 'room occupied' operating at a room controller set point of 22°C. Daikin was awarded the project for several reasons. These include: the smaller external footprint of the units; lower capital cost than would be required for four pipe fan coils; a high COP, which means lower running costs; two-stage heat recovery; lower CO₂ emissions; and adaptability to the hotel control system.

14 Port Elizabeth, South Africa Nelson Mandela Bay Stadium

PROJECT OUTLINE

Location Port Elizabeth, South Africa
 Application Stadium
 Project year 2010

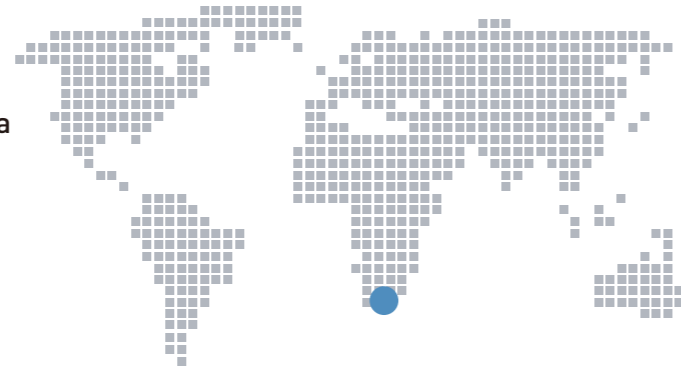

EQUIPMENT

Outside unit	Indoor unit
--------------	-------------

107 units	238 units
-----------	-----------

PROJECT COMMENTARY

This stadium is one of the three coastal stadiums built in anticipation of the 2010 FIFA World Cup. It regularly hosts large-scale rugby union and football (soccer) matches.

15 Cape Town, South Africa Green Point Stadium

PROJECT OUTLINE

Location Cape Town, South Africa
 Application Stadium
 Project year 2010

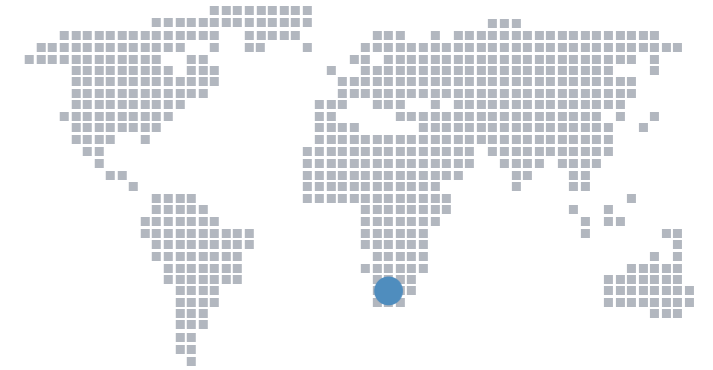

EQUIPMENT

Outside unit	Indoor unit
--------------	-------------

63 units	113 units
----------	-----------

PROJECT COMMENTARY

The stadium is located in Green Point, between Signal Hill and the Atlantic Ocean. This is a newly built stadium that was used for the 2010 FIFA World Cup.

16 Istanbul, Turkey Akasya Residence

PROJECT OUTLINE

Location Istanbul, Turkey
 Application Apartment
 Number of floors 40F
 Project year 2012

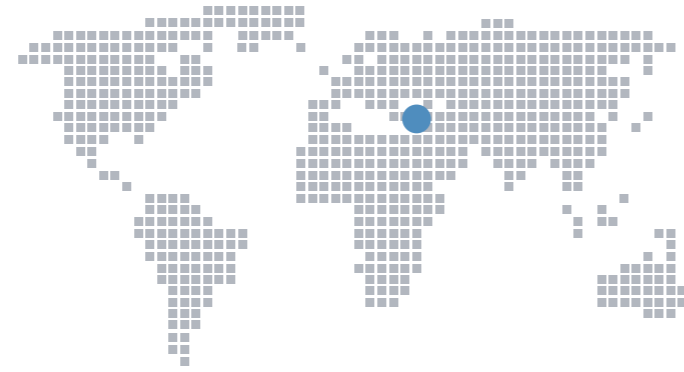

EQUIPMENT

Outside unit

RWEYQ10P × 87
 RXYQ8P × 23
 RXYQ10P × 8

RXYQ12P × 36
 RXYQ16P × 6
 RXYQ18P × 28

Indoor unit

FXCQ × 522
 FXAQ × 1397
 FXSQ × 578

Others

intelligent Manager × 12
 PPD Function

PROJECT COMMENTARY

This project is a complex project with total site area of 182,000 m² including parks, luxury residential units, sports, recreation and social facilities. Akasya shopping center with multi-purpose theater, cinemas, restaurants and health club are also included in the project. Residential units are composed of phase A and B. Daikin water-cooled VRV system (VRV-WIII) was installed on Phase A because of limited space for installing outside units. Daikin air-cooled VRV system was installed on Phase B. Round flow cassette, 2-way flow cassette and wall mounted indoor units are installed in each room. VRV system with intelligent Manager is the optimum solution to control air conditioning system.

17 Tottori, Japan Daikin Ales Aoya Global Training Center

PROJECT OUTLINE

Location Tottori, Japan
 Application Training Center
 Number of floors 6F
 Project year 2008
 Total floor area 16,541 m²



DESIGN DRAWING

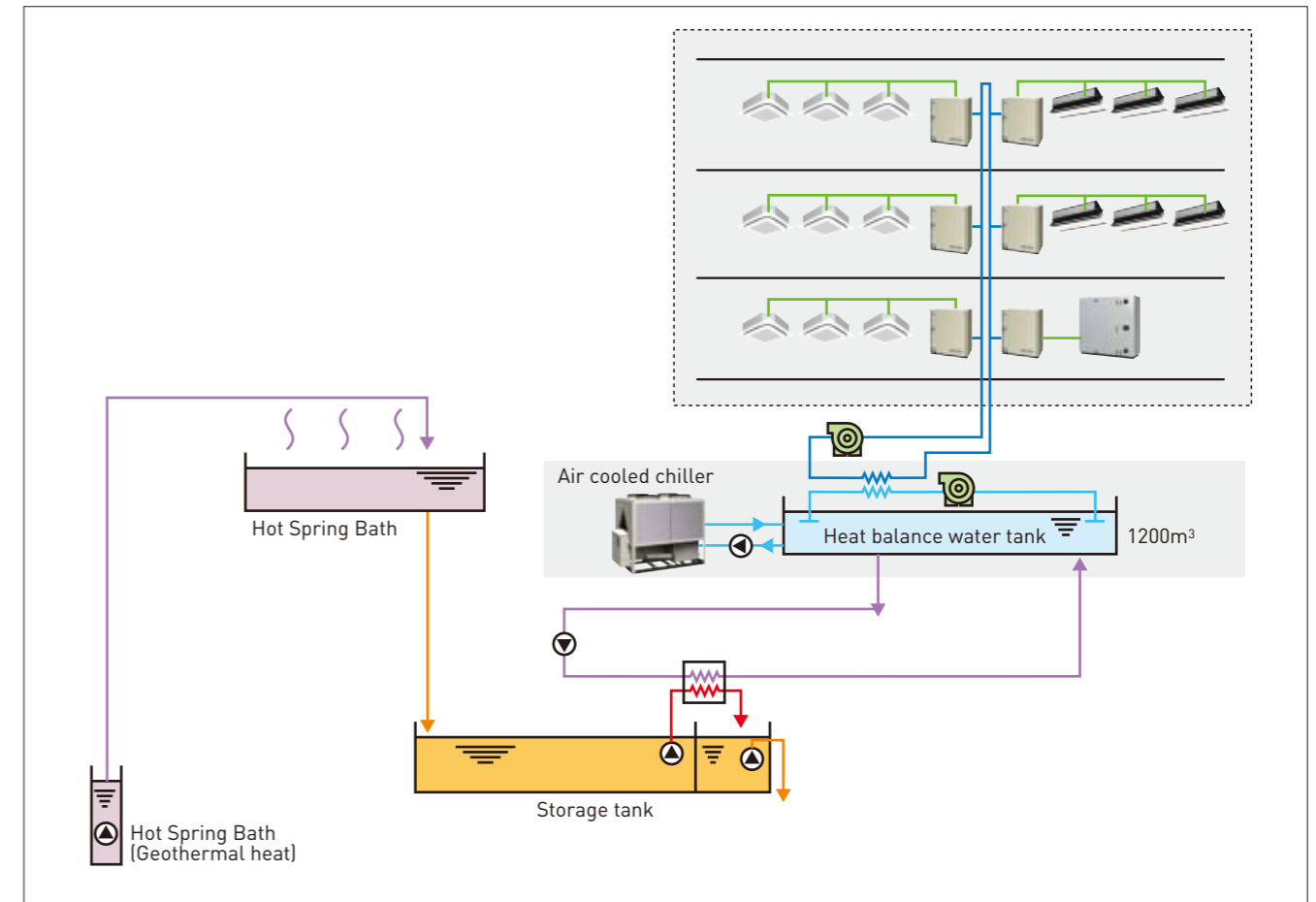

Fig-1 Usage of Geothermal Heat

EQUIPMENT

Outside unit

Water cooled VRV
 RWEYP224PR × 25 RWEYP560PR × 20
 RWEYP280PR × 25 RWEYP672PR × 6
 RWEYP448PR × 16

Indoor unit

FXYCP × 113 (2-way cassette) FXYWP × 11 (Wall built-in)
 FXYFP × 48 (Round flow cassette) FXYLP × 1 (Floor standing)
 FXYP × 41 (Duct) UAV × 4 (Direct expansion AHU)
 FXYDP × 13 (Slim Duct)

PROJECT COMMENTARY

Water-cooled VRV heat recovery system is installed in this facility. Heat recovery system is an optimum solution for hotel application. Remarkable point in this project is that air conditioning system (for heating) uses natural energy (geothermal heat). Air-cooled heat pump chiller is operated when geothermal heat is not sufficient. Heat balance tank is installed to store hot water or cold water made at night and they are used as an energy source of air conditioning system. Midnight electricity is cheaper than daytime electricity in Japan, thus using electricity at night can reduce electricity cost. On top of that, heat pump hot water supply system is applied to supply hot water of shower.

18 Shangyu, China Shangyu Baiguan Building

PROJECT OUTLINE

Location	Shangyu, China
Application	Office / Commercial complex
Number of floors	50F + B2F
Project year	2011
Total floor area	120,000 m ²



EQUIPMENT

Air cooled VRV × 5600 HP
Water cooled VRV × 920 HP

DESIGN DRAWING

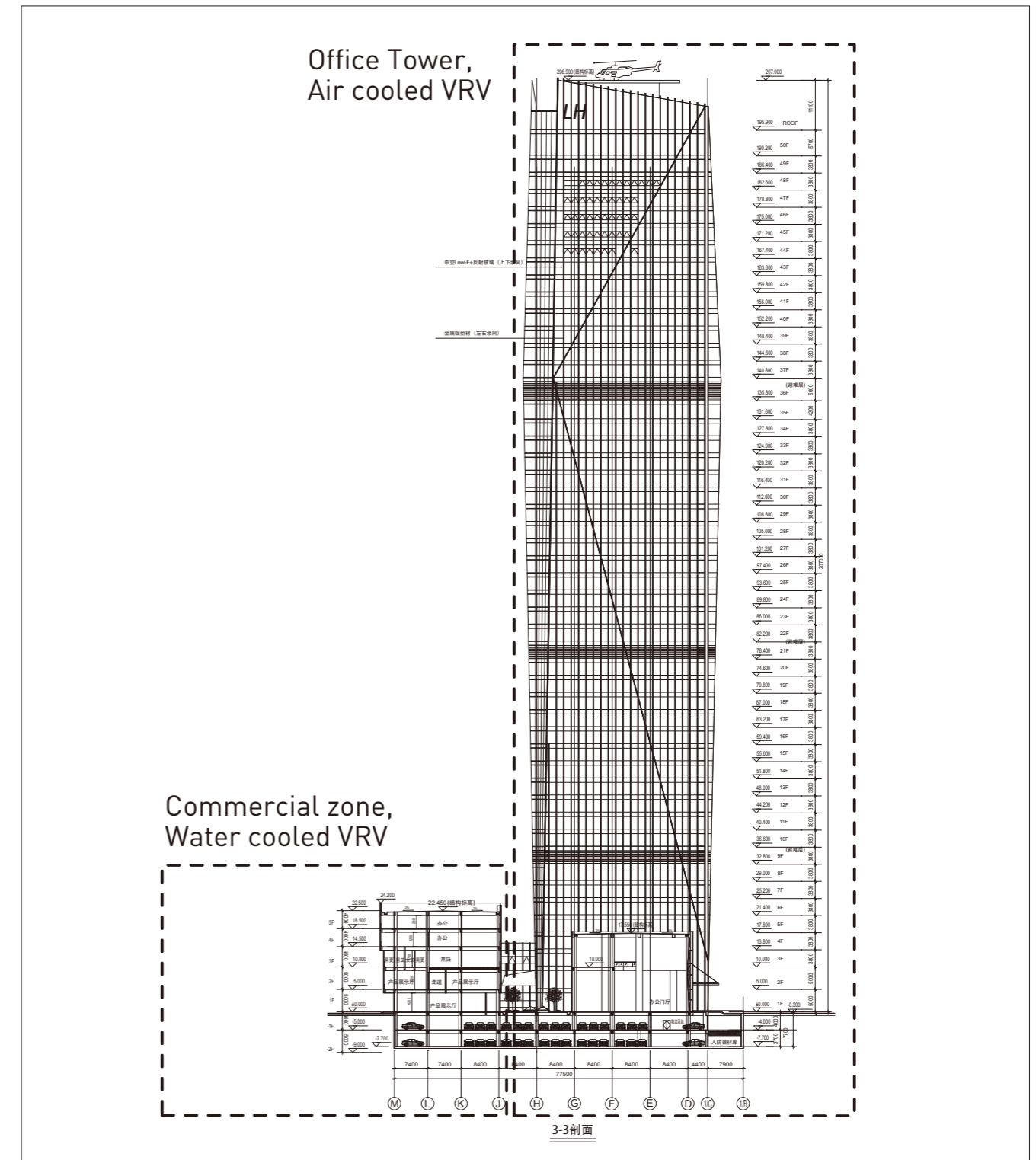

Fig-1 Overall Building Plan

PROJECT COMMENTARY

This building is air conditioned by air cooled VRV and water cooled VRV. Office tower is air-conditioned by air cooled VRV and commercial zone (hall, training gym, restaurant) is air-conditioned by water cooled VRV. VRV is suitable for high raised building like this project because of long refrigerant piping. Other advantages of VRV system are energy saving and small installation space.

19 Dalian, China Hengze Tiancheng

PROJECT OUTLINE

Location Dalian, China
 Application Office, Apartment
 Number of floors 22F
 Project year 2007
 Total floor area 110,296 m²



DESIGN DRAWING

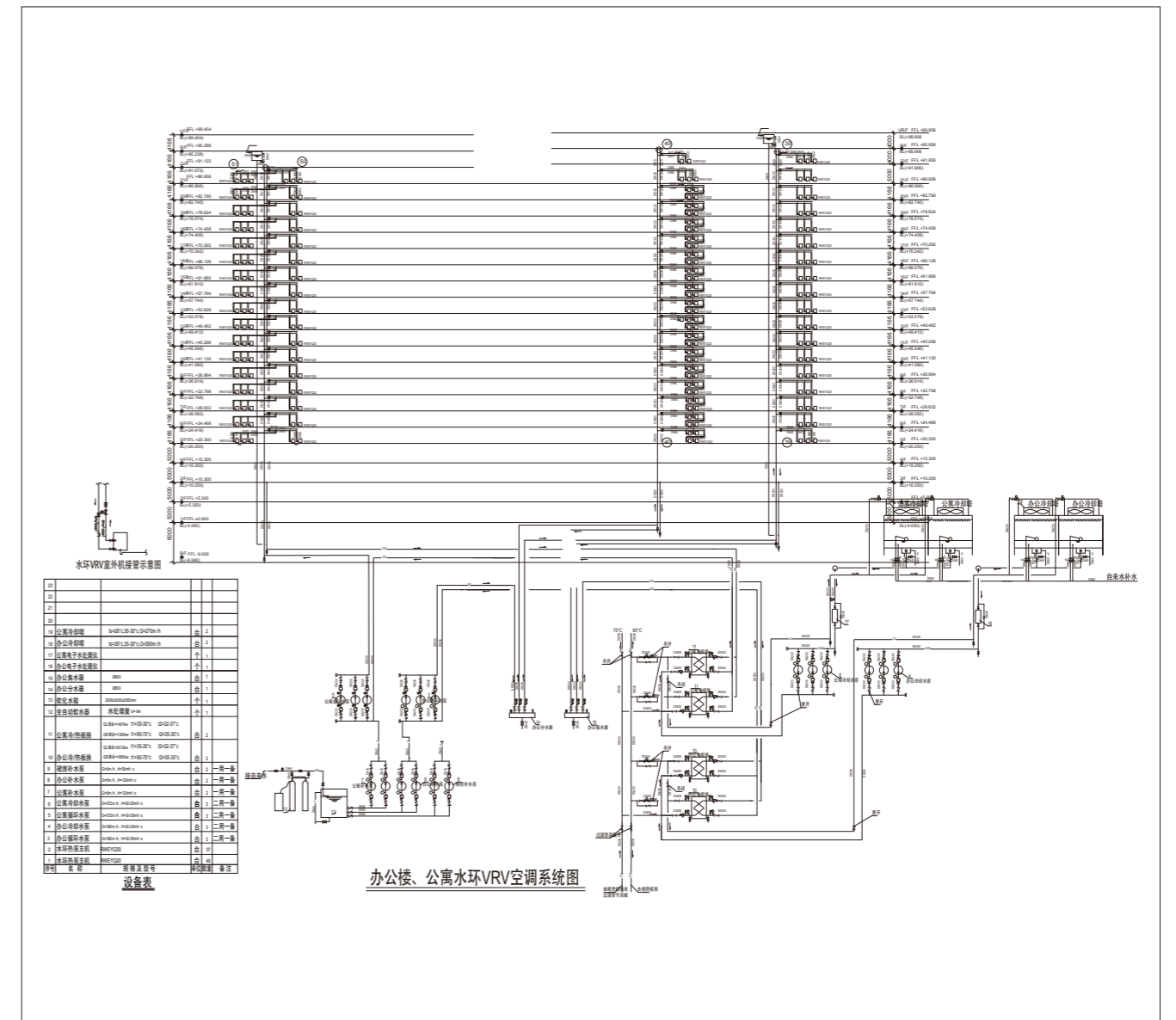

Fig-1 Schematic Diagram

EQUIPMENT

VRV-WII × 2,290 HP
 Water cooled chiller × 1,200 HP

PROJECT COMMENTARY

Water cooled VRV is installed because of following reasons;

1. Better heating capacity than competitor's one
2. Individual operation

Heat source in winter is district heating

20 Osaka, Japan Umeda Hankyu Building

PROJECT OUTLINE

Location	Osaka, Japan
Application	Department Store / Office
Number of floors	41F + B3F
Project year	2010
Total floor area	254,000 m ²



EQUIPMENT

Outside unit

Water cooled VRV × 549
Air cooled VRV × 13

Indoor unit

Duct type × 1,441
Ceiling suspended type × 13
Cassette type × 63

Others

Packaged air conditioner × 58
BS Units × 1,043

DESIGN DRAWING

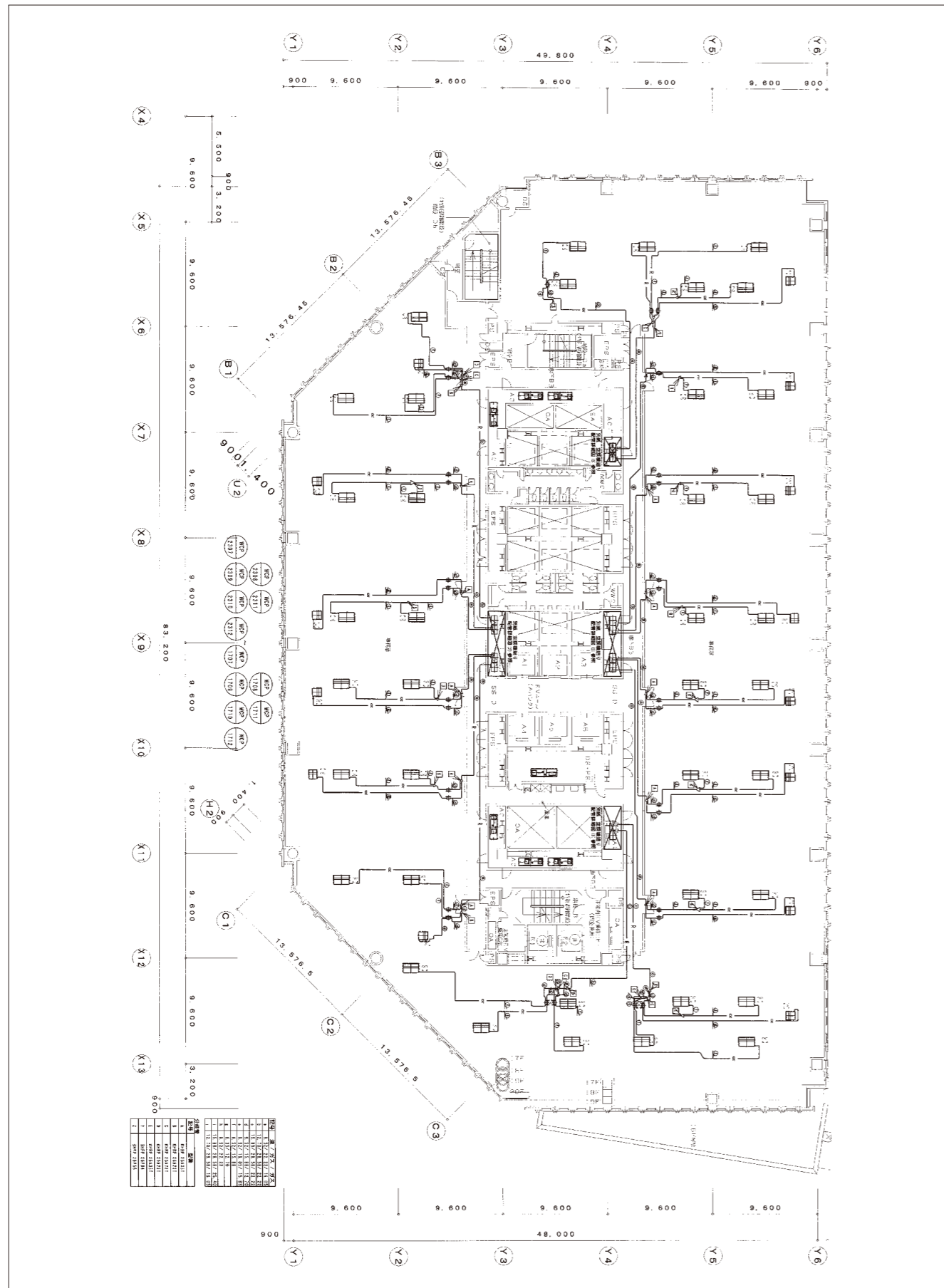

Fig-1 Floor Plan (17-23F)

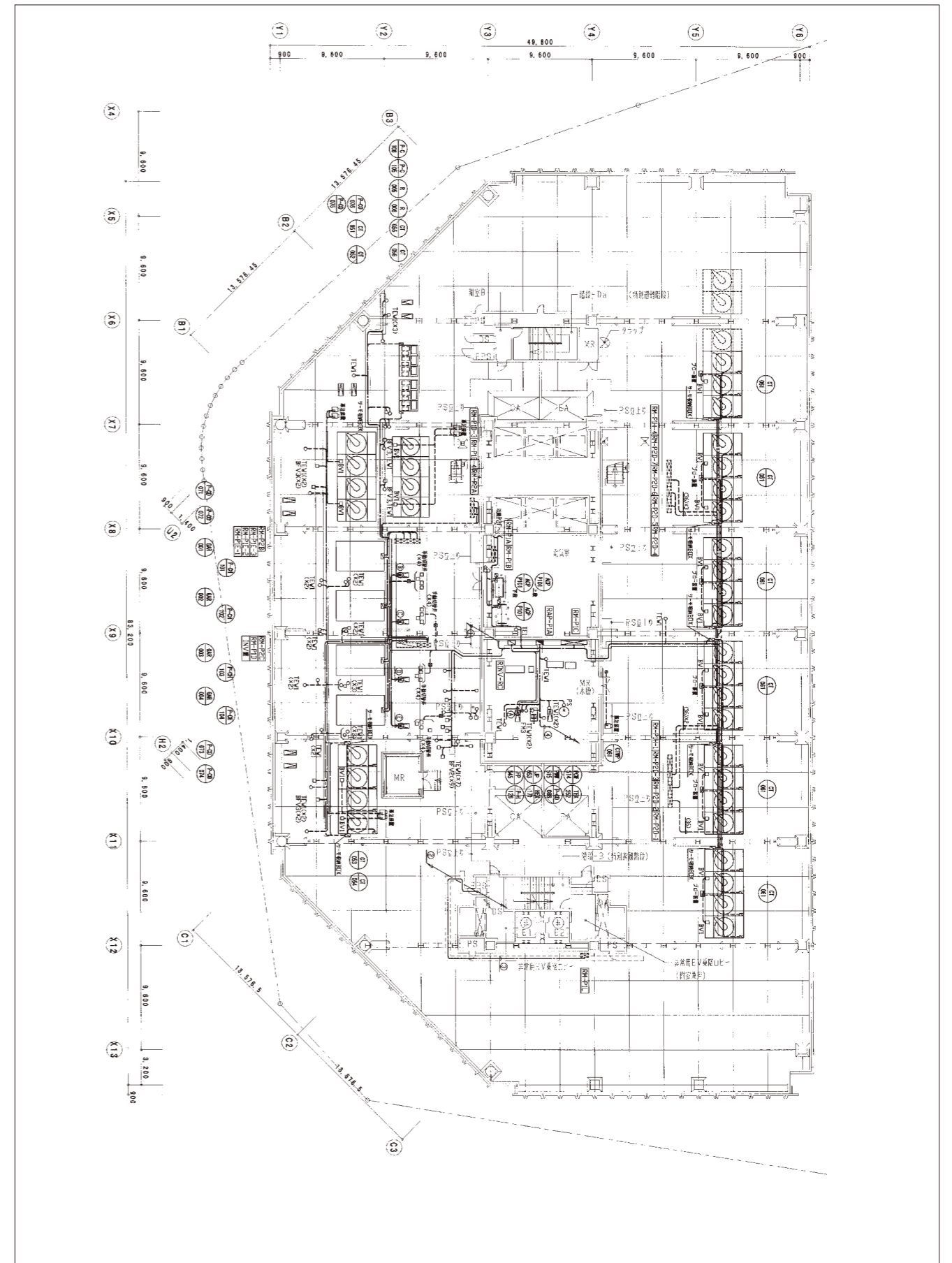

Fig-2 PH1F Floor Plan

DESIGN DRAWING

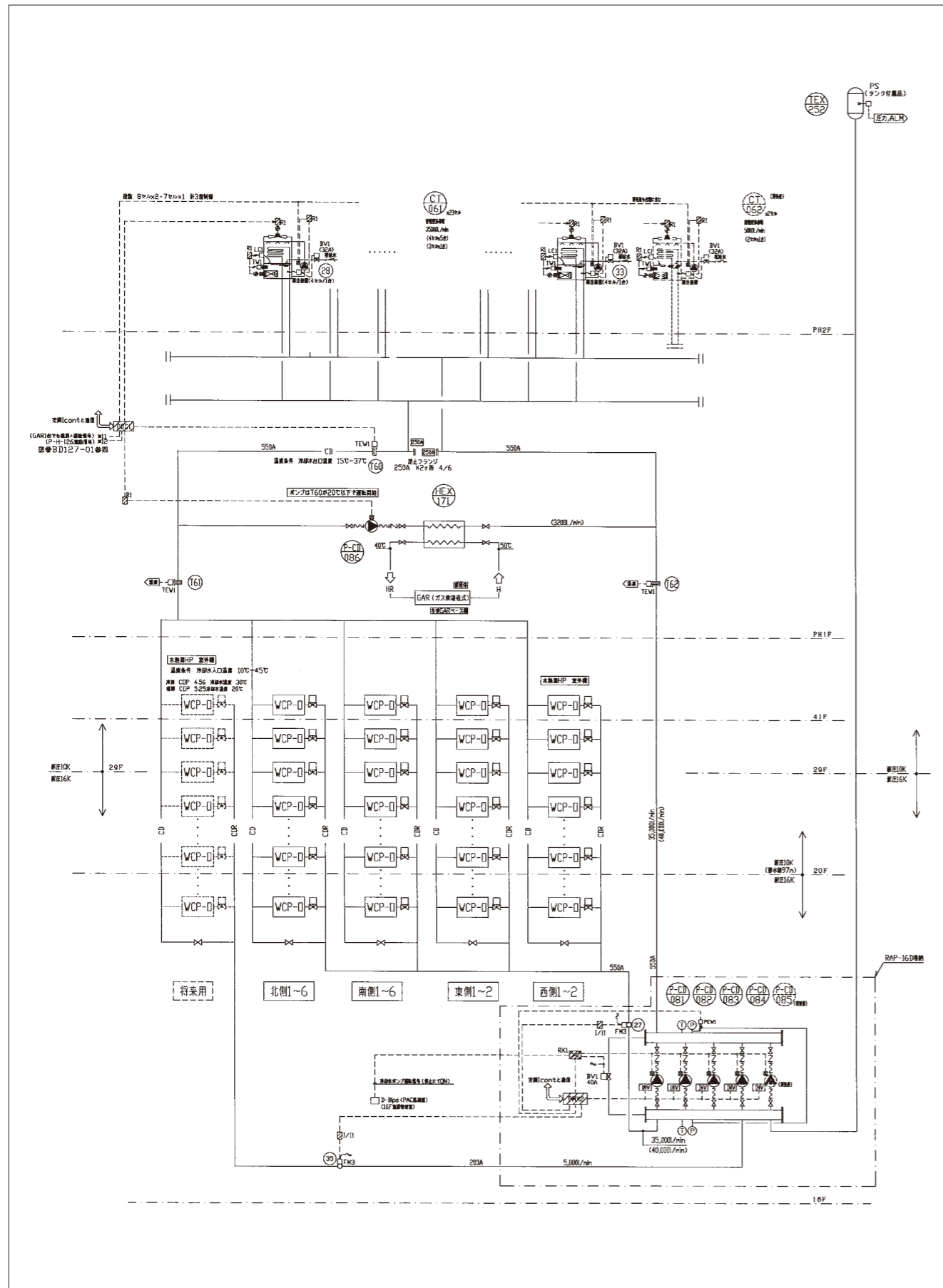

Fig-3 Schematic Diagram

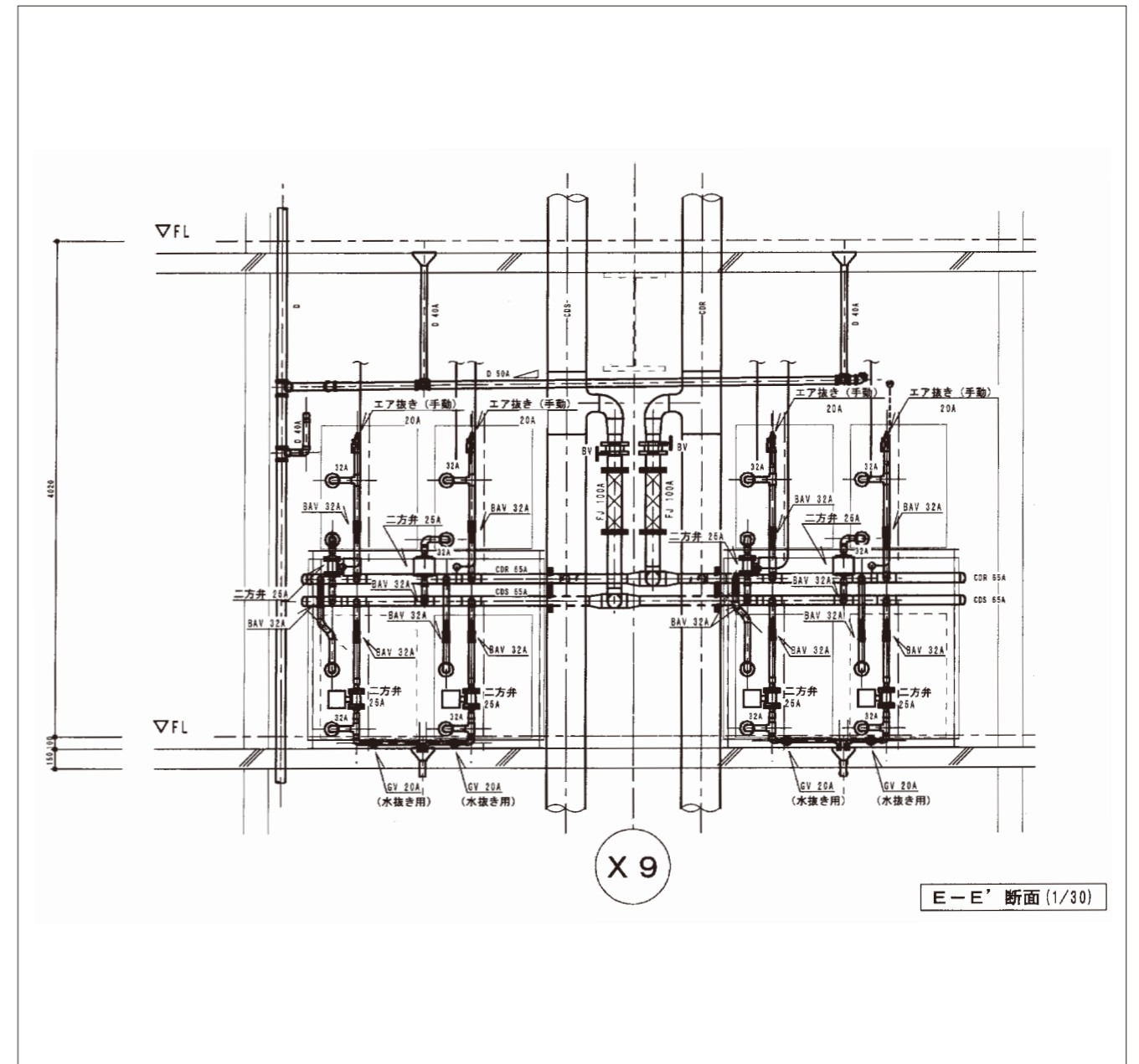

Fig-4 Piping Diagram

PROJECT COMMENTARY

The Umeda Hankyu Building houses one of the biggest department stores in Japan. Since the Umeda Hankyu Building was opened in 1929 as the world's first department store associated with a railway terminal, many extensions have been made to this building and it has aged. It is now completely rebuilt to become a new earthquake-proof complex. After rebuilding, there are 41 stories above ground and 2 below (for a total of 187 meters in height). There are offices in the upper stories, with the department store in the lower ones (13 stories above ground and 2 below). This building has a water-cooled VRV air conditioning system, which makes it a leading-edge building with important energy-saving features.